

Oil & Gas

**lindapter**<sup>®</sup>

Technical Innovation in  
Steelwork Connections



## Lindapter®

### Technical innovation in steelwork connections since 1934

Lindapter provides a unique range of approved steelwork solutions for overcoming challenging steel-to-steel connections. Our products are used extensively around the world and are the ideal solution for onshore and offshore applications in the oil and gas industry, with no site welding or drilling required.

Whether securing heavy duty pipe supports, electrical and instrumentation equipment, steelwork or steel flooring in new build or refurbishment projects Lindapter has a proven, accredited and safe connection solution.

If you are an Engineering, Procurement and Construction (EPC) Contractor then your projects and installations could benefit from Lindapter innovative steelwork clamping systems that provide a faster, safer and more cost-effective alternative to drilling or welding in hazardous environments.



#### CONTENTS

##### 3 Reasons to use Lindapter Connections

##### CONNECTIONS FOR...

4 - 11 Pipe Supports

12 - 15 Electrical & Instrumentation

16 - 21 Steelwork

22 - 25 Subsea

26 - 27 Lifting Points

28 - 33 Structural Hollow Section

34 - 35 Steel Flooring & Grating

36 - 37 Project Experience

38 Technical Support & Service

39 Accreditations & Approvals

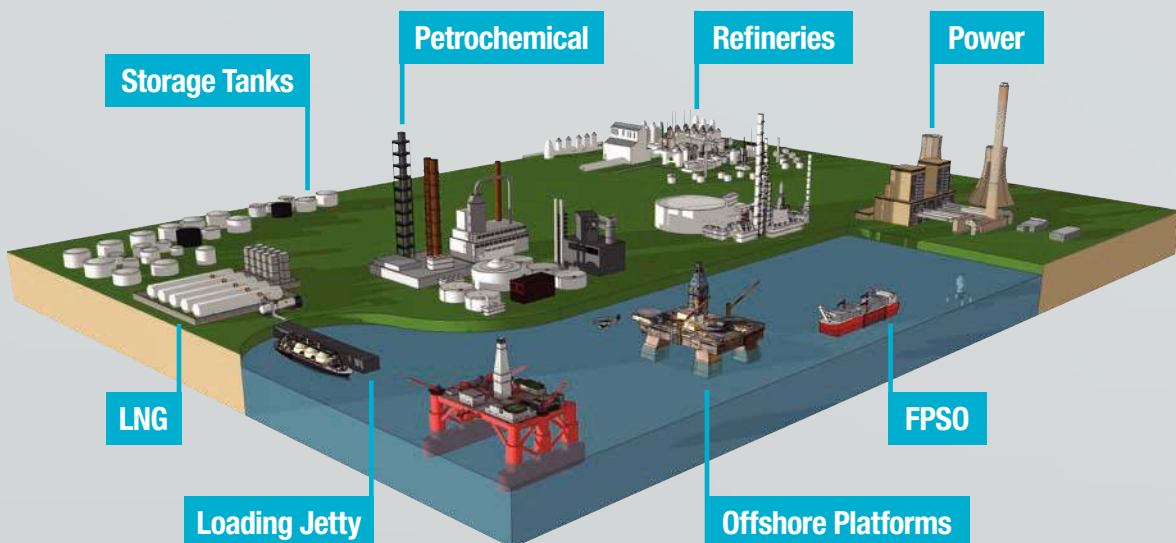

# Reasons to use Lindapter connections

## KEY BENEFITS



### No Welding

Say goodbye to the hazards and time-consuming process of welding. Lindapter allows for cold connections, eliminating the need for hot works, which increases safety and reduces onsite risk.



### No Drilling or Bolting

Traditional methods of securing steel require intensive labour and time. With Lindapter, you can bypass the need for drilling or bolting, preserving the integrity of structures and saving hours of labour.



### Speed Of Installation

Maximise productivity with quick and easy installation methods. Our solutions are designed to minimise project timelines, saving you valuable time and labour costs.



### Easy, Adjustable Installation

No need for heavy machinery or specialised equipment. Lindapter connections are installed using hand tools, allowing for easy adjustments and more flexible project management.



### Expert Installation Guidance

Benefit from installation guidance and ongoing support from our expert team. We are with you every step of the way to ensure smooth and successful project execution.



### Minimise Downtime

Reduce downtime associated with shutdowns and complex installations. Lindapter connections can be installed during live operations, ensuring minimal disruption to your project.



### Free Connection Detailing (see page 38)

Lindapter ensures you have all the information you need to make the right decision for your project, helping you save on design time and costs.



### Approvals (see page 39)

For over 90 years Lindapter has manufactured to the highest possible standards and has earned a respected reputation synonymous with safety and reliability due to its range of independent approvals.

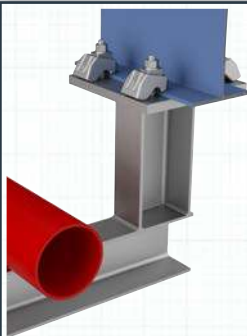

### GIRDER CLAMPS

Steel sections are clamped together using girder clamp assemblies for a quick installation. This connection method is used extensively in oil and gas applications including pipe support frames, hanger brackets and for connecting secondary steel to the primary structure.



### LIFTING POINTS

These assemblies support the lifting or rigging of general equipment. Can be used for single lift situations or permanent applications such as lowering risers from offshore platforms.

### HOLLO-BOLT & LINDIBOLT

Our expansion bolts require access to only one side of the Structural Hollow Section (SHS), and offer a faster alternative to welding or through-bolting, enabling contractors to reduce construction time and labour costs.



### FLOOR FIXINGS

A range of innovative fixings for securing steel flooring to the supporting steelwork without the need for onsite drilling or welding. Access to the underside of the flooring is not required, eliminating the need for costly scaffolding or elevated floors.

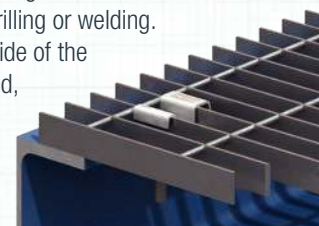

# Pipe Supports

**Lindapter girder clamps are a popular choice for connecting steel sections together to create pipe support structures that carry heavy duty pipelines around oil and gas installations.**

By simply clamping the steel together with girder clamps, pipe supports can be installed without welding, drilling or any other hot works. As a result operational downtime is minimised, a safer work environment is achieved and risks vastly reduced.

The ability to adjust girder clamps onsite is particularly beneficial as steel sections that make the pipe supports can be moved and aligned into the exact positions required before the clamps are fully tightened using just hand tools.

Lindapter offers a range of weld and drill free solutions for tensile and slip connections that are quick and easy to install, making them the ideal choice for all types of pipe support applications.

## KEY BENEFITS



- ✓ No welding or drilling
- ✓ No hot works
- ✓ Solutions for every type of pipe
- ✓ High tensile and slip load capacities

## SPOTLIGHT ON...



### No Welding!

- ✓ No hot work, minimises fire risk and no need for area closures.
- ✓ No expensive welding labour, only hand tools required.
- ✓ No hot work permit, suitable for use in hazardous areas.

# Pipe Supports

## PROJECT EXAMPLE

### WHITEMOOR INSTALLATION

**Location:** Selby, UK

**Application:** Connecting steel sections together to create pipe support structures to carry heavy duty pipelines around the plant.

**Solution:** Lindapter Type AF & Type A Girder Clamps

Engineers wanted a safe and secure method of connecting steel sections together to create pipe support structures that would carry heavy duty pipelines around the plant. They also required adjustability to allow for pipe installation tolerances, this was important at critical locations such as pipeline joints. Another consideration was the risks associated with hot works which ruled out welding as an option.

Lindapter worked with the engineer to design several connections using girder clamps. Type AF high slip resistance girder clamps were specified for both tensile and frictional connections of the heavy duty pipes to the support structures. Type A girder clamps were used for tensile connections of smaller, lighter duty pipes.

The Type AF offers the highest load capacities of all Lindapters high slip resistance girder clamps making it the ideal choice for this heavy duty application whilst also avoiding the risks associated with welding.

#### Key Benefits

- ✓ High load capacities for heavy duty application
- ✓ No welding or hot works
- ✓ Fully adjustable onsite for easy installation

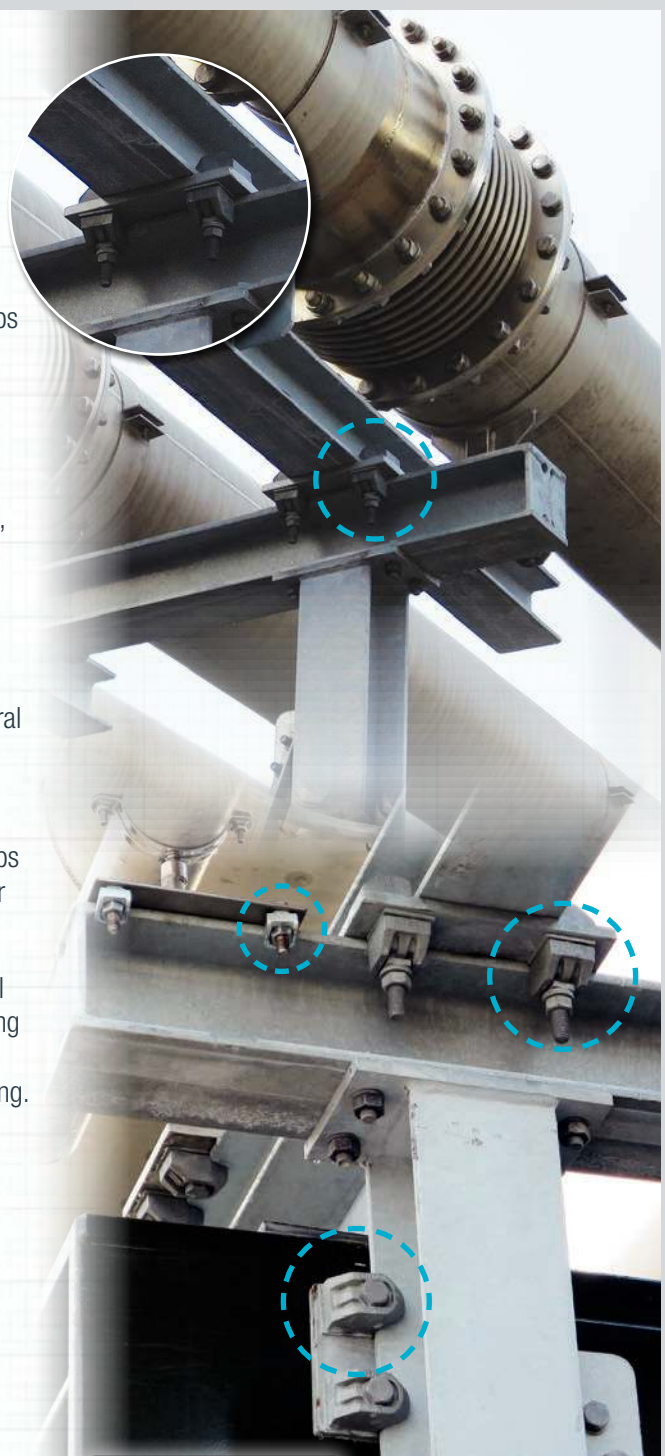
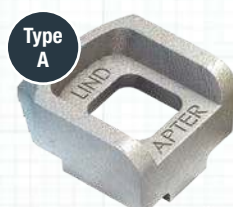
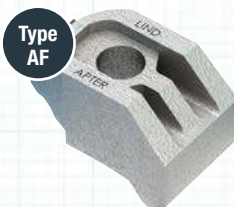

Read more examples  
of Lindapter's technical  
solutions on our website  
[www.Lindapter.com](http://www.Lindapter.com)

# Pipe Supports

## PROJECT EXAMPLE

### EXXONMOBIL REFINERY

**Location:** Baytown, Texas, USA

**Application:** Securing pipe guides to existing steel in readiness for a new pipeline to be installed.

**Solution:** Lindapter Type LR Girder Clamps

Lindapter's adjustable Type LR girder clamps were used to install "L" shaped pipe guides along a new pipeline spanning several thousand feet without any interference to plant production.

The new pipeline was installed running adjacent to the existing piping and supported by existing cantilever beams. The design specified that pipe guides should be installed to prevent any flexing from thermal expansion.

Avoiding hot work permits and related fire hazards of traditional welding and drilling methods, Lindapter provided the ideal solution with its Type LR that enabled pipe guides to be installed with simple hand tools and minimal interference.

The Type LR is suitable for various beam thicknesses and slopes which enabled the contractor to use a single product across the entire length of the pipeline.

#### Key Benefits

- ✓ No welding or drilling
- ✓ No hot works
- ✓ No plant closure or downtime

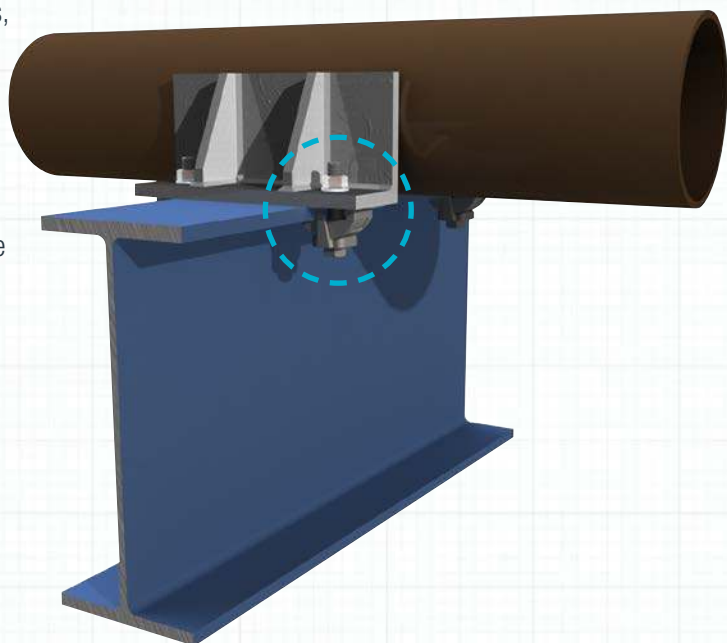

Read more examples  
of Lindapter's technical  
solutions on our website  
[www.Lindapter.com](http://www.Lindapter.com)

# Pipe Supports

## OTHER LINDAPTER SOLUTIONS

### PIPE SUPPORT CHANNEL TO BEAM

Heavy duty Type AF girder clamps are used to connect channel to the primary steel beam to provide support for pipework.

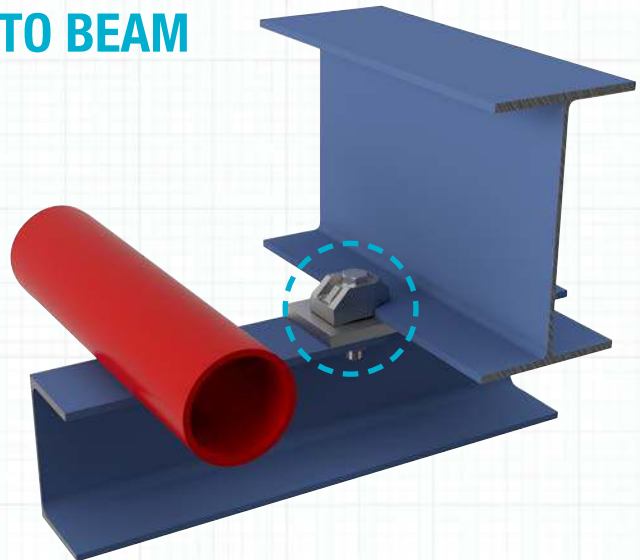
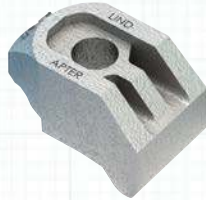

### PIPE SUPPORT HANGER TO BEAM

High strength Type AAF girder clamps are used to connect a pipe support hanger with end plate to a structural beam.

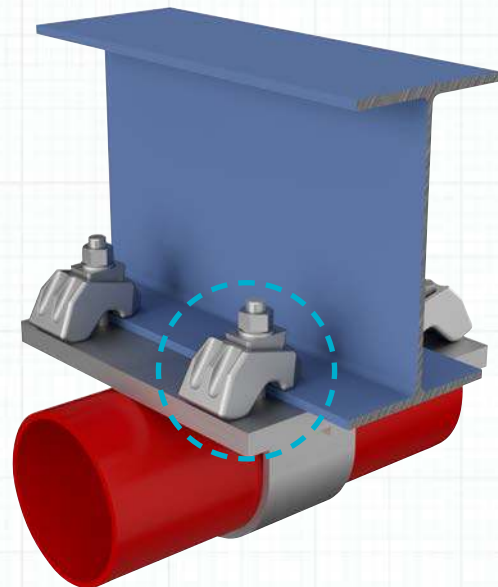
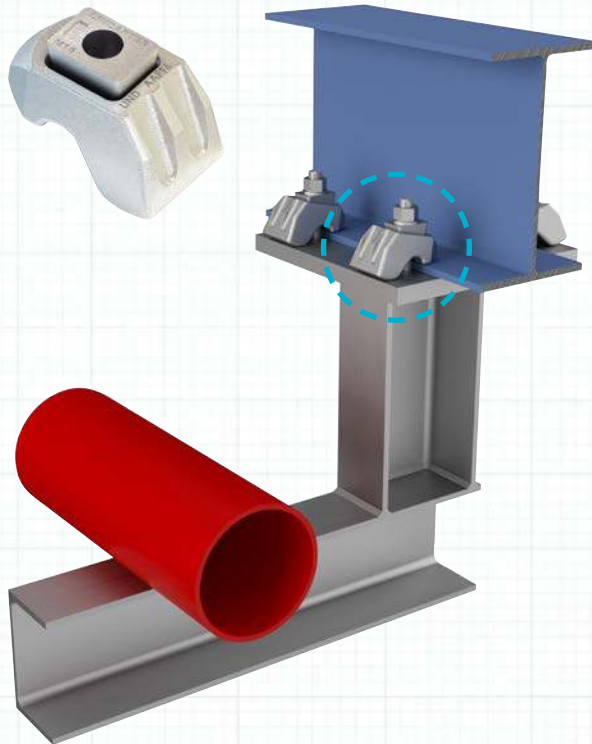

### PIPE SUPPORT STRAP TO BEAM

High strength Type AAF girder clamps are used to connect pipe support straps to the steel beam.



# Pipe Supports

## OTHER LINDAPTER SOLUTIONS

### PIPE GUIDES TO BEAM

Type LR adjustable girder clamps are used to connect "L" shaped pipe guides to beam.

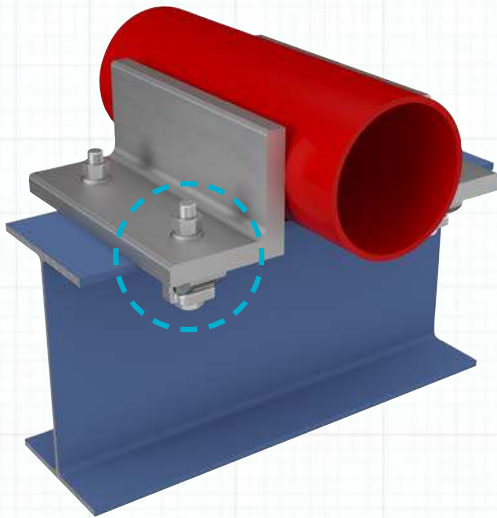

### PIPE SUPPORT HANGER TO BEAM

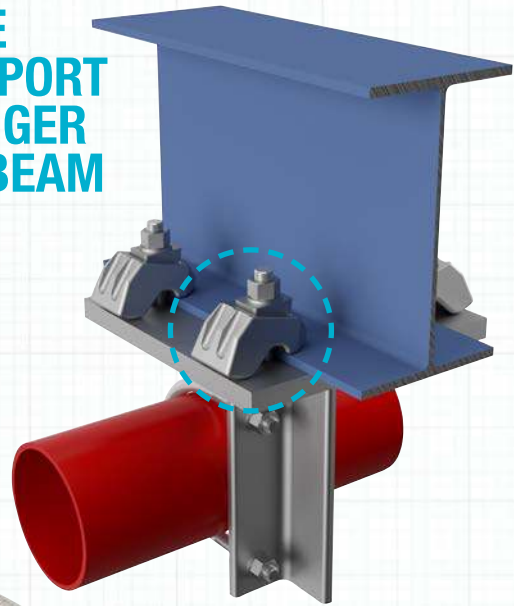

High strength Type AAF girder clamps are used to connect a pipe support hanger with strap to beam.

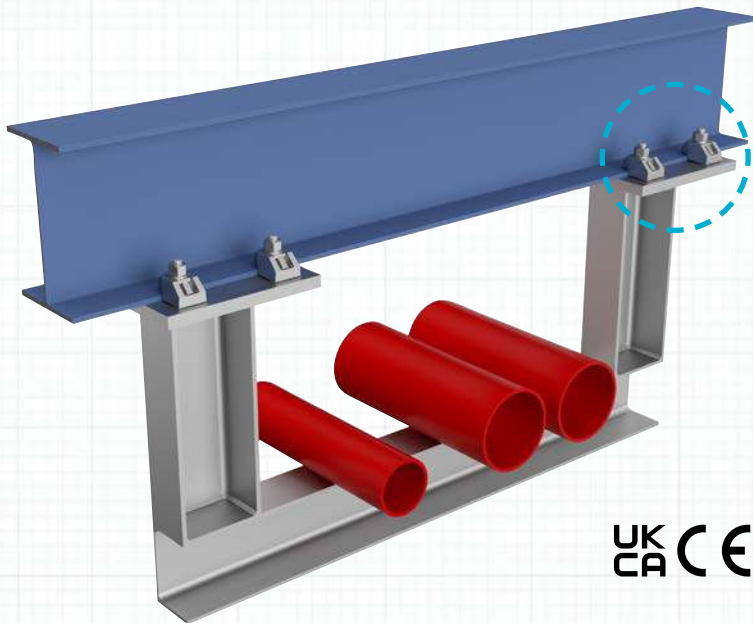

### PIPE SUPPORT HANGER TO BEAM

Heavy duty Type AF girder clamps are used to connect a pipe support cradle to the primary steel.

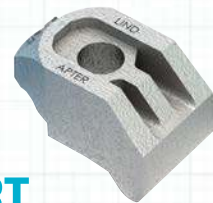

# Pipe Supports

## OTHER LINDAPTER SOLUTIONS

### PIPE SUPPORT BEAM TO COLUMN

High slip resistance Type AF girder clamps are used to connect a pipe support beam with end plate to a structural column.

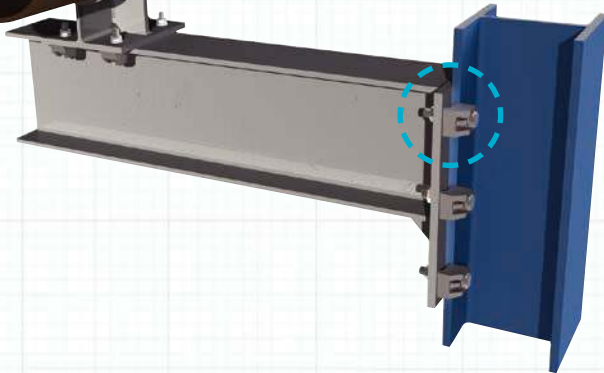
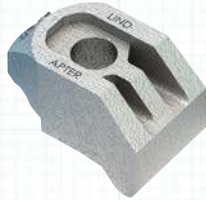

### PIPE SUPPORT SADDLE TO BEAM AND COLUMN

Heavy duty Type AF girder clamps are used to connect the beam to the column and the pipe support saddle to the beam.



### PIPE SUPPORT BEAM SPANNING TWO COLUMNS

High slip resistance Type AF girder clamps are used to connect a beam with an end plate on each end to columns to create the pipe support structure.

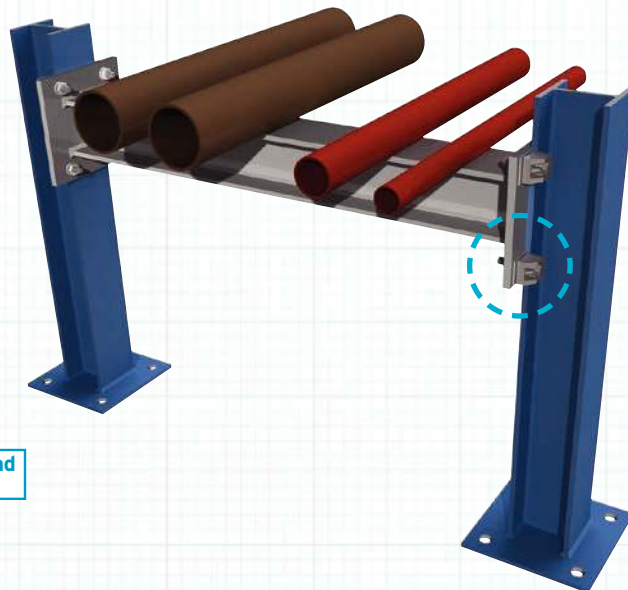
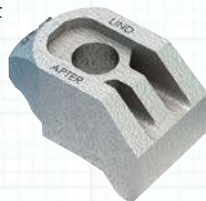

# Pipe Supports (Light Duty & MEP)

## STRUT CHANNEL SOLUTIONS

### STRUT CHANNEL TO BEAM

High strength Type AAF adjustable girder clamps are used to connect a strut channel support frame to the steel beam. Light duty piping or other MEP services can then be suspended from the strut channel.

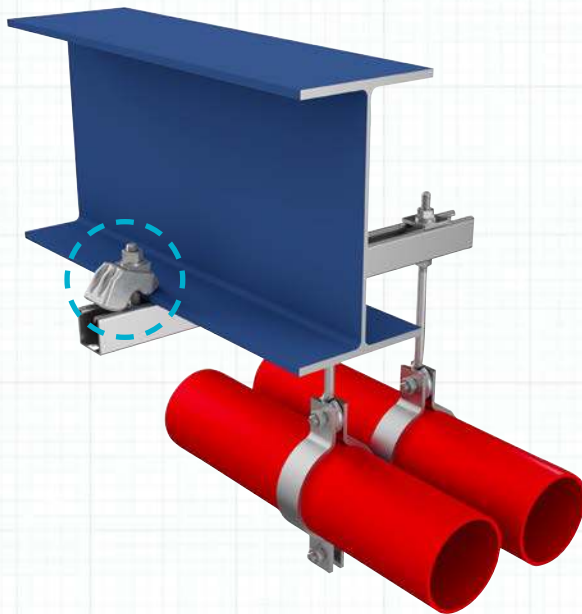
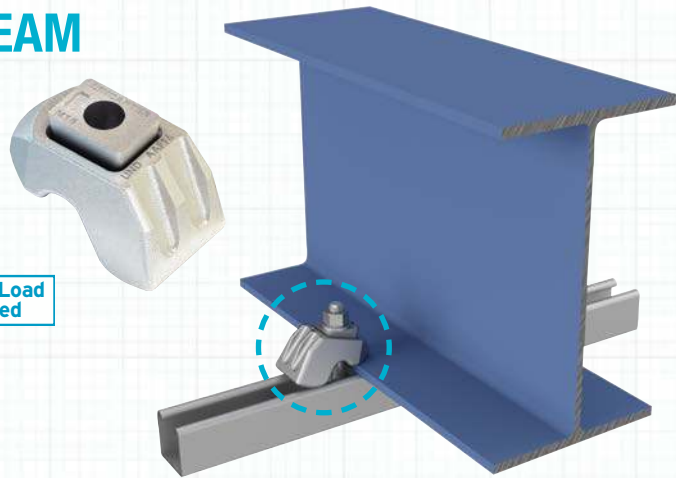

### CANTILEVER STRUT CHANNEL TO BEAM

High strength Type AAF adjustable girder clamps are used to connect strut channel with opening upwards to the steel beam. Threaded rod and pipe brackets hold light duty piping or other MEP services.



### STRUT CHANNEL SUPPORT TO ANGLE TRUSS

High strength Type AAF adjustable girder clamps are used to connect strut channel with opening upwards to angle truss. The support can be used to hold light duty piping or other MEP services.

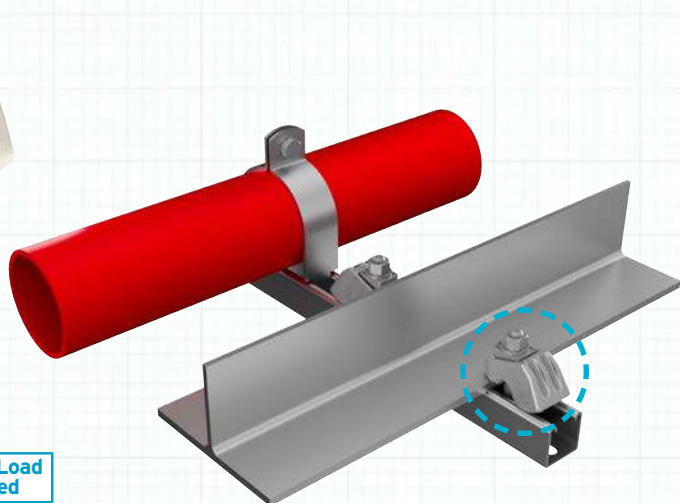

# Pipe Supports (Light Duty & MEP)

## STRUT CHANNEL SOLUTIONS

### STRUT CHANNEL SUPPORT TO COLUMN

Type CF high slip resistance girder clamps are used to connect strut channel to the flanges of the steel column. The support can be used to hold light duty piping or other MEP services vertically.

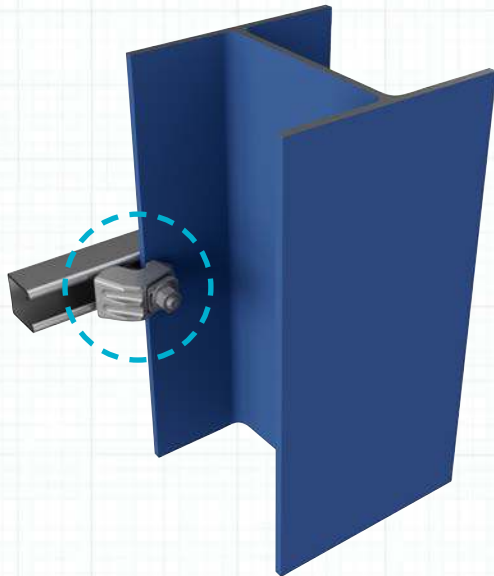
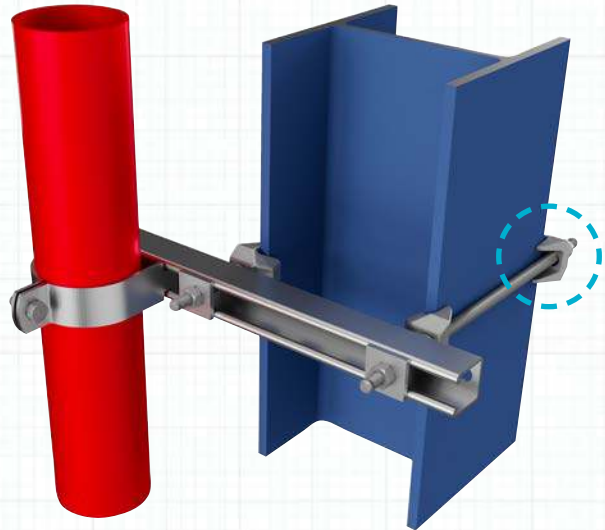

### STRUT CHANNEL FRAMEWORK TO COLUMN

Type AAF adjustable girder clamp used to create a high slip resistance connection between the strut channel framework and the steel column. Light duty piping or other MEP services can then be suspended from the strut channel.



### HEAVY DUTY CHANNEL SYSTEM TO COLUMN

Type AAF high slip resistant girder clamps with location plates are used to connect heavy duty channel systems to the primary steel columns. The channel system is then used to support multiple types of MEP services including pipework and electrical cable tray.

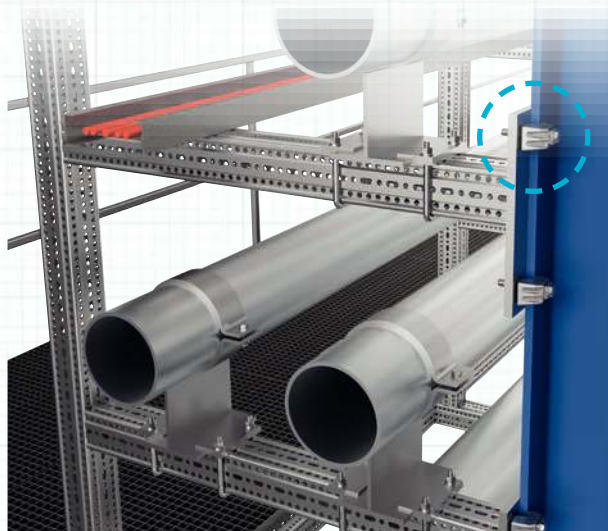

# Electrical & Instrumentation

**Lindapter girder clamps are a popular choice for connecting heavy duty electrical cable ladder hangers and supports to steelwork to carry heavy duty cables and electrical equipment around oil and gas installations.**

By simply clamping the ladder hangers and supports to the primary or secondary beams with girder clamps, welding, drilling or any other hot works is avoided. As a result, operational downtime is minimised, a safer work environment is achieved and risks vastly reduced.

The ability to adjust girder clamps onsite is particularly beneficial as the hangers and supports can be moved and aligned into the exact positions required before the clamps are fully tightened using just hand tools. Lindapter offers a range of weld and drill free solutions for tensile and slip connections that are quick and easy to install, making them the ideal choice for all types of electrical and instrumentation applications.

## KEY BENEFITS



- ✓ No welding or drilling
- ✓ No hot works
- ✓ Adjustable onsite for easy installation
- ✓ High tensile and slip load capacities

## SPOTLIGHT ON...



### Easy, adjustable installation!

- ✓ Only simple hand tools required to install, no heavy machinery or specialised equipment.
- ✓ Complete onsite adjustability avoids remedial work, delays and increased costs.

# Electrical & Instrumentation

## PROJECT EXAMPLE

### PETROCHEMICAL PLANT

**Location:** Suape, Brazil

**Application:** Securing electrical cable ladder hangers and supports to steelwork.

**Solution:** Lindapter Type A Girder Clamps

Heavy duty steel support trees and hangers were connected to the primary steelwork of this petrochemical plant using Lindapter Type A Girder Clamps in a four-bolt configuration. The large industrial sized electrical cable ladders were then secured to the steel supports and the cabling installed. No drilling, welding or hot works were required making the installation in this hazardous environment safe for everyone on the site.

#### Key Benefits

- ✓ Safe installation with no hot works required
- ✓ No expensive welding required
- ✓ Fully adjustable onsite for easy installation

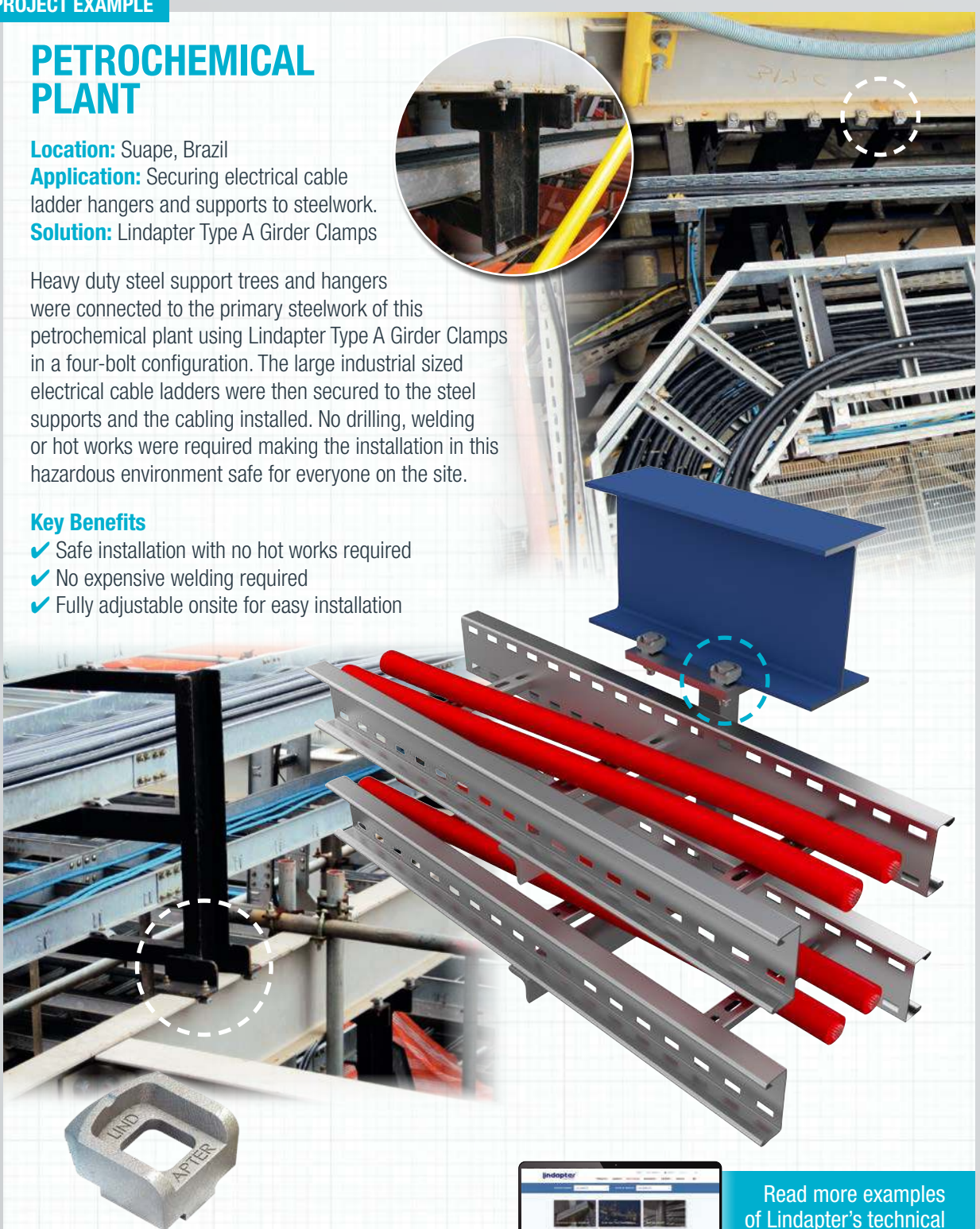

Read more examples of Lindapter's technical solutions on our website [www.Lindapter.com](http://www.Lindapter.com)

## PROJECT EXAMPLE

### BIOETHANOL PLANT

**Location:** Anklam, Germany

**Application:** Securing electrical cable ladder hangers and supports to steelwork.

**Solution:** Lindapter Type A Girder Clamps

Heavy duty steel support trees and hangers were connected to the primary steelwork of this plant using Lindapter Type A Girder Clamps in a four-bolt configuration. The large industrial sized electrical cable ladders were then secured to the steel supports and the cabling installed.

No drilling, welding or hot works were required making the installation in this hazardous environment safe for everyone on the site.

#### Key Benefits

- ✓ Safe installation with no hot works required
- ✓ No expensive welding required
- ✓ Fully adjustable onsite for easy installation



Read more examples of Lindapter's technical solutions on our website  
[www.Lindapter.com](http://www.Lindapter.com)

## OTHER LINDAPTER SOLUTIONS

### CABLE TRAY SUPPORT CONNECTED TO BEAM

Heavy duty Type AAF girder clamps are used to connect steel support hangers to the beams. Cable tray or ladder is then installed on the support arms.

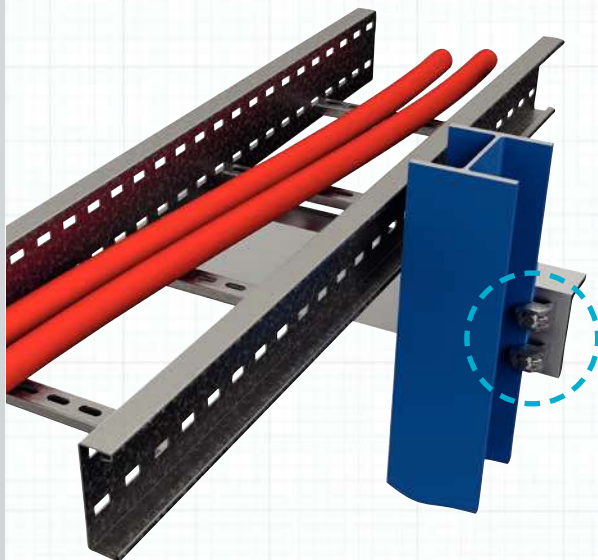
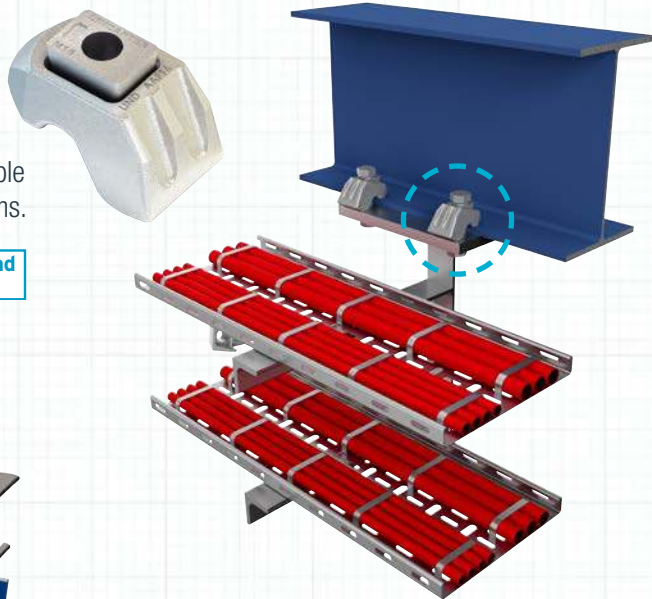

### CABLE LADDER SUPPORT CONNECTED TO COLUMN

Type AF high slip resistance girder clamps connect support arms to the column. Cable ladder or cable tray is then installed on the support arms.

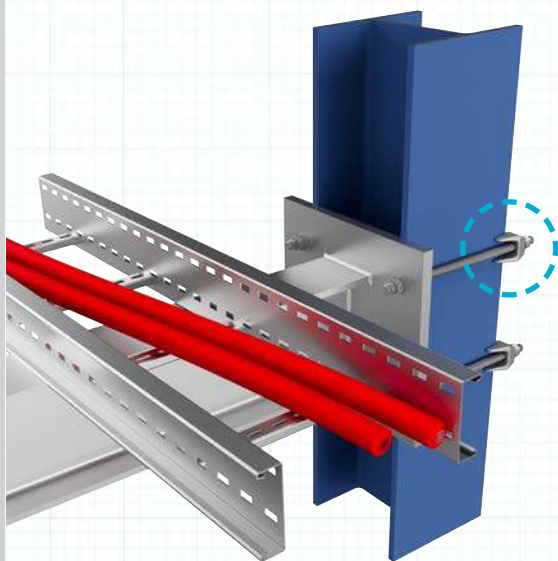

### CABLE LADDER SUPPORT TO COLUMN FLANGES

Type CF high slip resistance girder clamp are used to connect steel support beams with end plate to the flanges of the steel column. Cable ladder or cable tray is then installed on the support arms.



# Steelwork



**Lindapter girder clamps are a popular choice for connecting secondary steelwork, whatever shape and size and in a wide variety of applications for oil and gas projects.**

By simply clamping steel sections together with girder clamps, welding, drilling or any other hot works is avoided. As a result operational downtime is minimised, a safer work environment is achieved and risks vastly reduced whilst also preserving the structural integrity of the primary steel. The ability to adjust girder clamps onsite is particularly beneficial as the steelwork can be moved and aligned into the exact positions required before the clamps are fully tightened using just hand tools to create a high strength and safe connection.

Lindapter offers a range of weld and drill free solutions for tensile and slip connections that are quick and easy to install, making them the ideal choice for all types of steel-to-steel applications in either new construction projects or refurbishment of existing structures.

## KEY BENEFITS



- ✓ No welding or drilling
- ✓ No hot works
- ✓ Adjustable onsite for easy installation
- ✓ High tensile and slip load capacities

## SPOTLIGHT ON...



### No drilling or welding!

- ✓ No welding or hot works, minimises fire risk.
- ✓ No expensive welding labour, only hand tools required.
- ✓ No drilling or bolting preserves the integrity of the steel.

## PROJECT EXAMPLE

### PLATFORM DECK EXPANSION

**Location:** South China Sea, offshore Malaysia

**Application:** Beam to beam connection to secure temporary landing beams during the expansion of the platform deck.

**Solution:** Lindapter Type A & Type B Girder Clamps

The M1 Liquefied Natural Gas (LNG) platform operated by Shell in the South China Sea was undergoing expansion to allow the installation of an additional gas compression train. Drilling and welding of the existing structural steelwork was not permitted so the offshore installation contractor used Lindapter Type A and Type B girder clamps with packing pieces and location plates to connect temporary landing beams to the existing steelwork.

No drilling, welding or hot works were required on the platform making the installation in this hazardous environment safe for everyone.

#### Key Benefits

- ✓ Safe installation with no hot works required
- ✓ No expensive welding required
- ✓ Temporary connection, simple to deconstruct

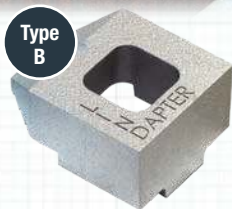
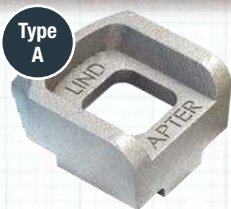

Read more examples of Lindapter's technical solutions on our website [www.Lindapter.com](http://www.Lindapter.com)



## PROJECT EXAMPLE

### PLATFORM HELIDECK REFURBISHMENT

**Location:** North Sea, offshore United Kingdom

**Application:** Securing a new aluminium helideck to the Centrica, Rough Alpha 47/8A gas platform.

**Solution:** Lindapter Type A & Type B Girder Clamps

Engineers made the decision to refurbish the corroding helideck, and required a connection solution that avoided galvanic corrosion. Lindapter provided bespoke girder clamps with synthetic polymer coatings to prevent electrical contact between the structural steel and aluminium deck.

The Type A and Type B girder clamps were installed without drilling or welding, preserving steelwork integrity. Lindapter's adjustable clamping systems allowed precise alignment of interlocking helideck parts and were calculated to withstand dynamic loads from helicopters. No hot work permits were needed, ensuring minimal productivity interruption and rapid, safe installation with cost benefits.

#### Key Benefits

- ✓ Synthetic polymer coating prevented galvanic corrosion
- ✓ No drilling or welding preserved steel integrity
- ✓ Adjustability allowed precise alignment of the helideck

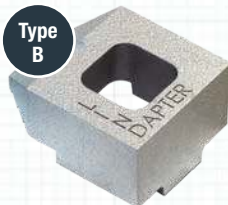
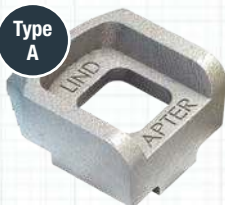
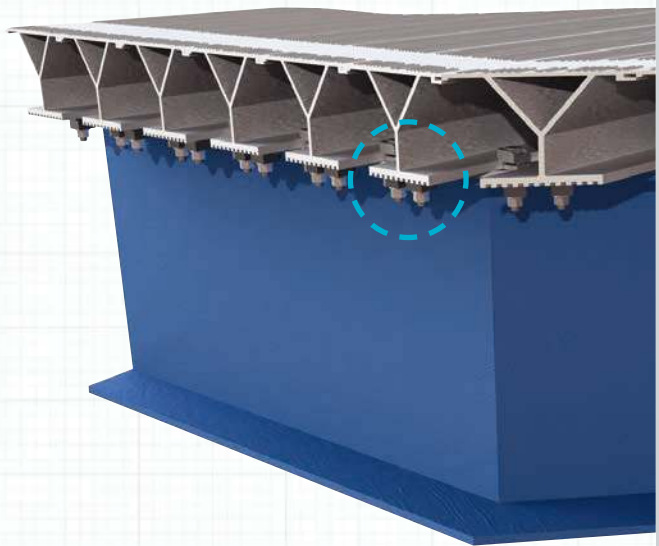

Read more examples of Lindapter's technical solutions on our website [www.Lindapter.com](http://www.Lindapter.com)

## OTHER LINDAPTER SOLUTIONS

GC01

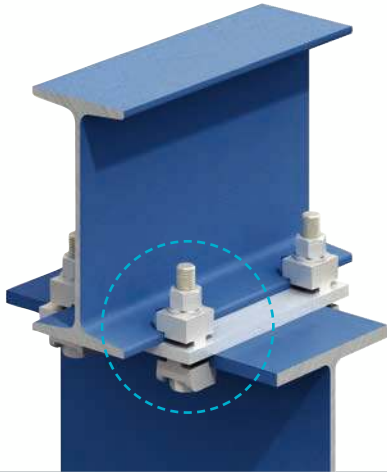

GC02

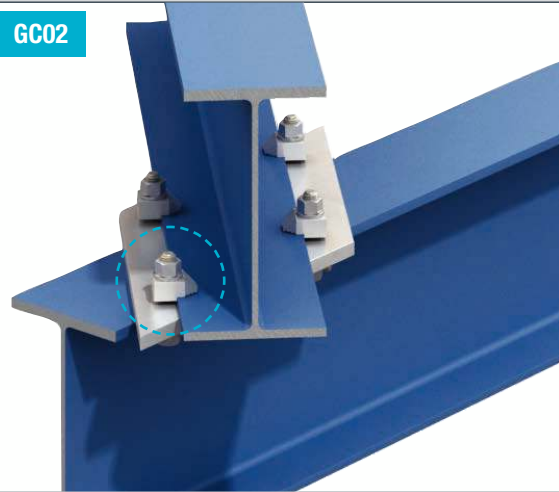

GC04

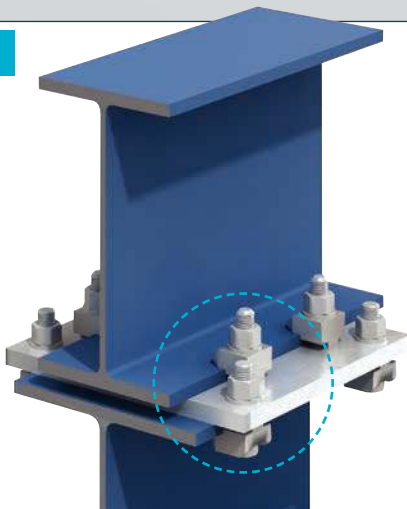

GC41



GC11



GC07



## OTHER LINDAPTER SOLUTIONS

GC09



GC10

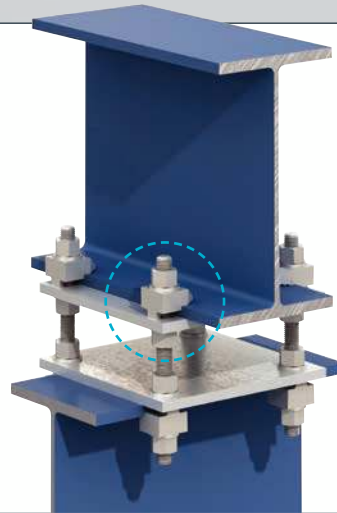

GC03



GC06

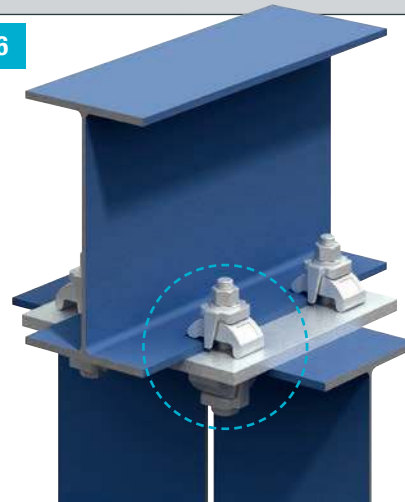

GC14

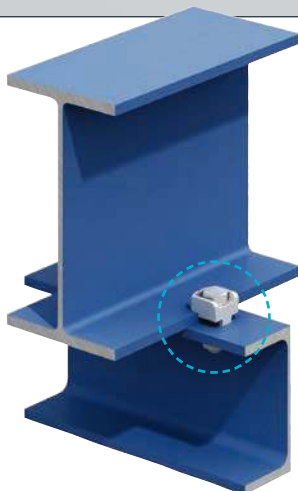

GC16

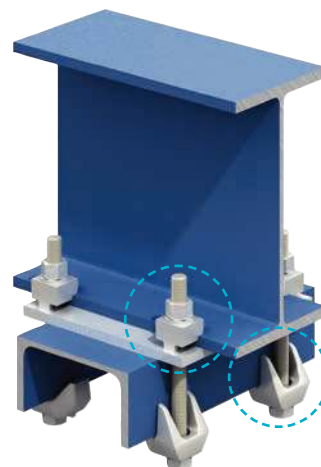

## OTHER LINDAPTER SOLUTIONS

GC30

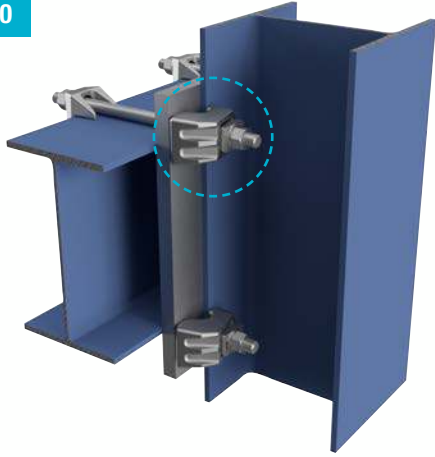

GC31

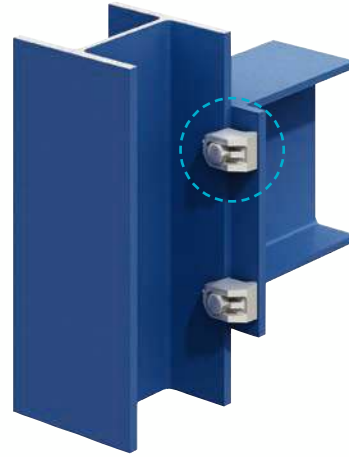

GC32

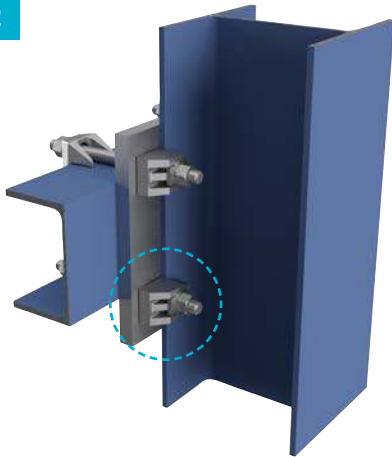

GC33

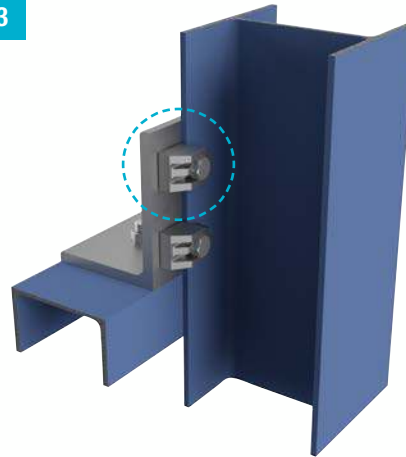

GC34

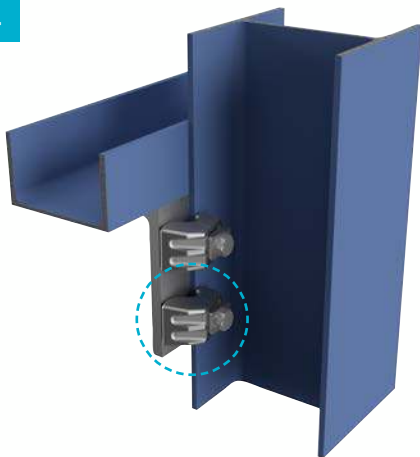

GC36

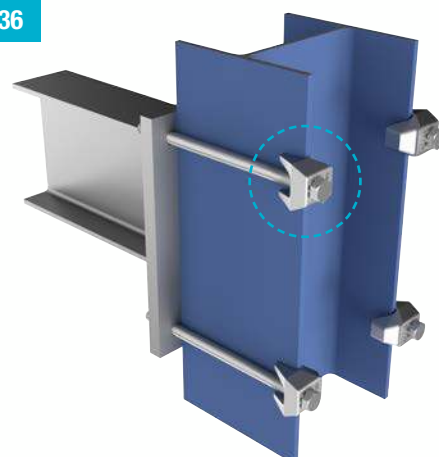

## PROJECT EXAMPLE

### AVIAT GAS FIELD DEVELOPMENT

**Location:** North Sea, offshore United Kingdom

**Application:** Securing the subsea production riser to the base support frame.

**Solution:** Lindapter Type AF Girder Clamps

Lindapter's girder clamps were selected by Apache North Sea Subsea Engineers and then installed by divers more than 100m below sea level to secure the production riser on the Forties Alpha platform to the base support frame for the Aviat Field Development project.

Apache's Structural Design Engineers were tasked with finding a robust connection to secure the production riser's supporting framework. The brief required a connection that would withstand high loads and outlive the production riser, while providing a quick way for the divers to carry out the installation while wearing thick gloves underwater.

Corrosion resistance and fatigue life were of paramount importance as the application needed to be able to support the weight while handling wave action on the host platform and movements from internal pressure in the production riser for over 15 years.

Various conventional connections were evaluated, and some were immediately rejected because the exact position of the joint was unknown whereas the adjustable Lindapter clamping systems prevented this from being a problem. Apache took advantage of Lindapter's free connection design service, and they quickly received a detailed proposal which was secured with heavy duty size M24 Type AF Girder Clamps, manufactured from SG iron with a hot dip galvanised coating as standard.

**Continued on next page...**



## PROJECT EXAMPLE CONTINUED

**“... it is very difficult to find equipment that is simple to assemble when working with thick gloves underwater. The divers assembled the Lindapter Type AF clamps quickly and I would be very happy to use products of this design going forward.”**

Jack Marston, Project Engineer

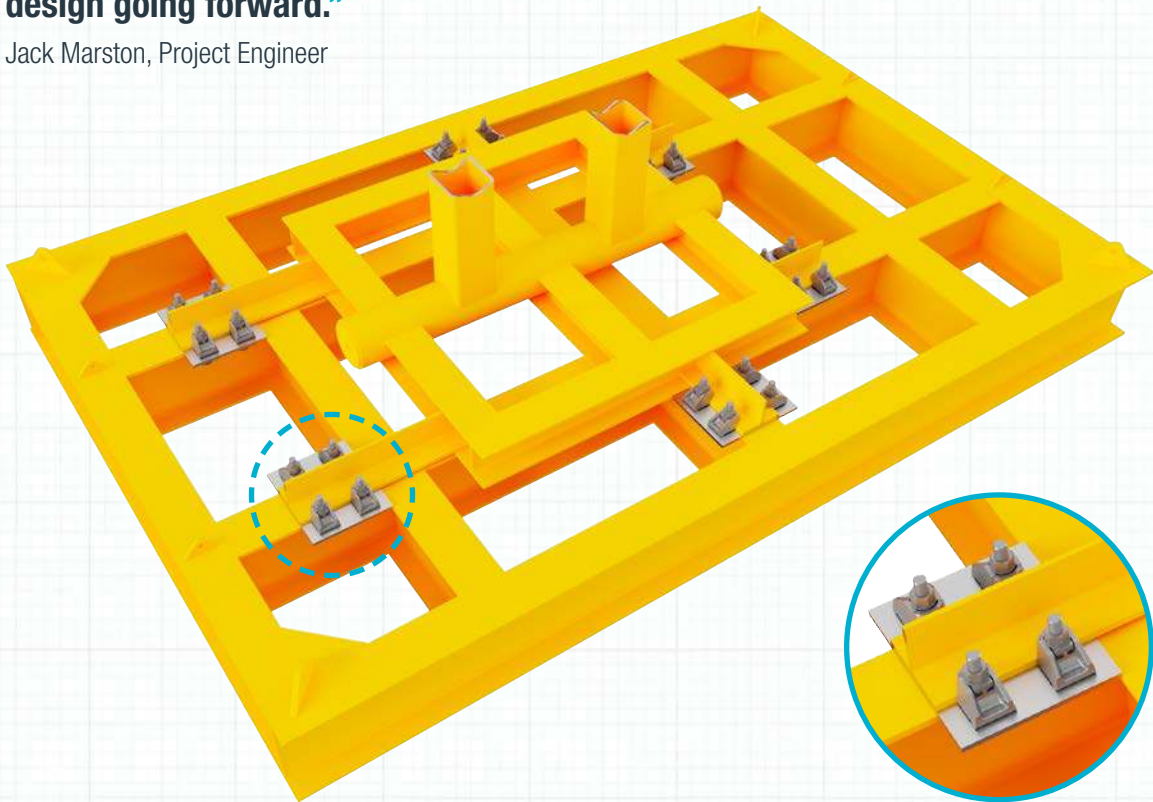

Lindapter's proposed solution was specified because it provided the tensile and slip resistance that was required for the loads anticipated during the life of the production riser. The clamping method simplified the design issues, installation process and operational activities for improvements in long term reliability, such as a reduced need for inspection and maintenance. Engineers were sure Type AF was the right choice as it offers independently approved safe working loads and superior corrosion resistance, which is ideal for subsea applications.

During installation, the divers benefited from the Type AF's lateral adjustability which allowed the framework to be quickly positioned and tightened using just simple hand tools. Jack Marston, the Project Engineer, commented on how quick and simple it was to secure the application with thick gloves underwater and that they will use girder clamps by Lindapter for future projects.

### Key Benefits

- ✓ High tensile and slip resistance capacities.
- ✓ Easy to install underwater while wearing thick gloves.
- ✓ Hot dipped galvanised finish offers high corrosion resistance.



## PROJECT EXAMPLE

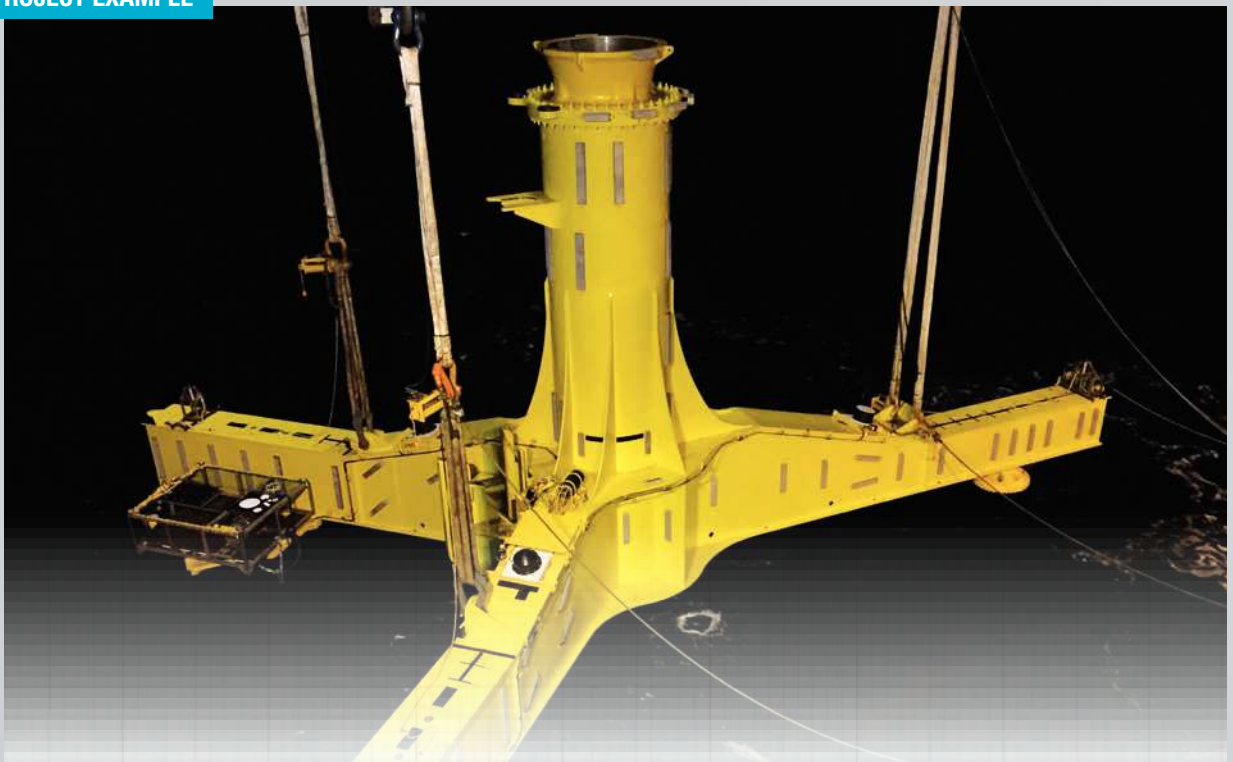

## MEYGEN TIDAL TURBINE PROJECT

**Location:** North Sea offshore North East Scotland

**Application:** Securing an instrumentation sled onto a tidal turbine foundation.

**Solution:** Lindapter Type AF Girder Clamps

Atlantis Resources Limited is pioneering the development of tidal current power as the most reliable, economic and secure form of renewable energy. Their Structural Design Manager specified Lindapter clamping systems for securing a steel platform onto a tidal turbine foundation on MeyGen, the world's most high profile tidal stream project.

Atlantis was commissioned to design the electrical and mechanical infrastructure needed to tie several subsea measurement instruments into one system in order to monitor the marine environment. Engineers determined that the monitoring equipment would be housed in instrumentation sleds and mounted on steel platforms each weighing up to 4000kgs.

**Continued on next page...**



## PROJECT EXAMPLE CONTINUED

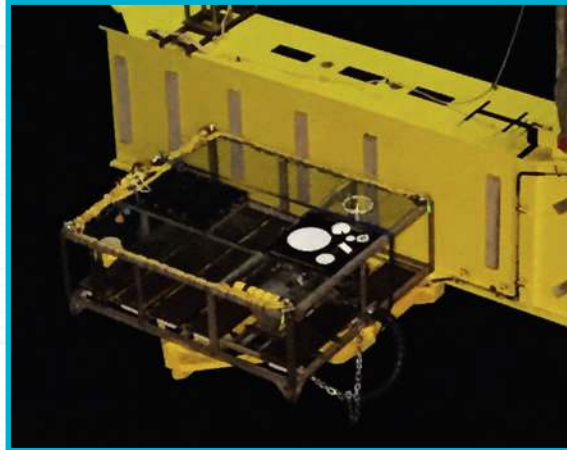

Engineers then sought a reliable connection to attach each platform to the Tidal Support Structure (TSS) as the instruments were to be hard-wired to the structure and had to be installed with the foundation.

The brief required a weld-free connection that would withstand tidal forces and outlive the life of the instrumentation sled and platform in order to avoid any unnecessary subsea servicing. Atlantis evaluated several fixings for strength, longevity and reliability and decided Lindapter's clamping systems were the best choice. After contacting Lindapter's technical team, the Engineer was confident that size M24 Type AF high slip resistant clamps should be used to attach the steel platform back to the flange of the tidal turbine support structure.

Further reassurance was provided by Lindapter's range of independent technical approvals and over 90 years' experience in designing and manufacturing steel connections. The Type AF's lateral adjustability allowed the installers to quickly align the platform into position before tightening with hand tools. The simple installation helped the contractor to save time and reduce labour costs on the project.



# Lifting Points

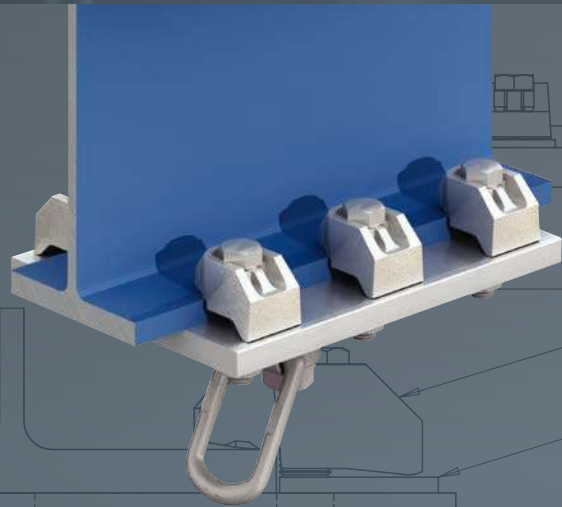
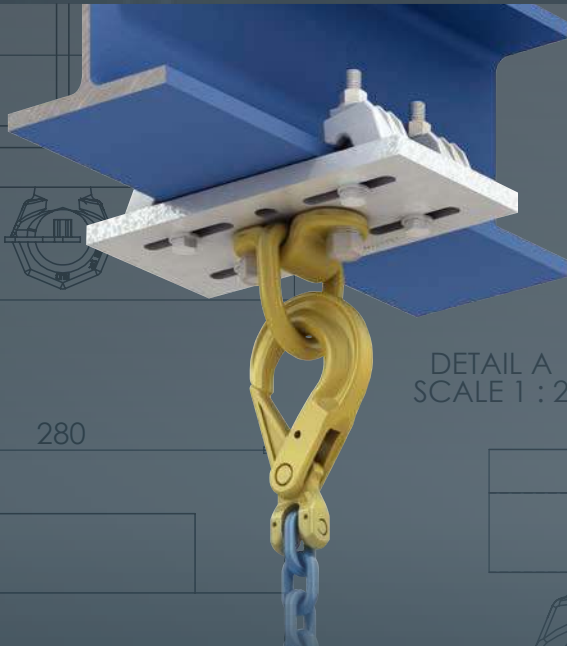

**Lindapter's high-quality lifting points are used in a variety of industries to support the lifting and rigging of heavy equipment.**

They are ideally suited to applications in the oil and gas industry where extreme environmental and weather conditions are present, as they do not require any welding or drilling to install and are available with high levels of corrosion protection.

Our lifting point solutions provide stability and safety during the operations of lifting and lowering drilling tools, risers and other associated equipment and are manufactured to meet the highest standards of quality, strength, and reliability, ensuring dependable performance even in the harshest environments.

## KEY BENEFITS



- ✓ Quick and easy to install
- ✓ No welding or drilling
- ✓ Corrosion protection to suit application
- ✓ Customised connections to suit requirements
- ✓ Supplied with load ring or eye bolt
- ✓ High load capacities up to 200kN

## SPOTLIGHT ON...



## Free connection detailing

Lindapter can design a bespoke connection based on your specific requirements free of charge. Our Technical Support Engineers will supply customised CAD drawings and BIM compatible files to complement your designs. Simply email [support@Lindapter.com](mailto:support@Lindapter.com)

# Lifting Points

## PRODUCT RANGE

### TYPE ALP

**Available 'off-the-shelf' with safe working load up to 3t (29.4kN)**

Standard rigging and lifting solution utilising Type AAF clamps, ideal for most applications up to 3t (29.4kN).

This assembly self-adjusts to suit a range of flange thicknesses and for further convenience, the slotted holes in the location plate allow the clamp to adapt to different beam widths, often allowing contractors to use just one type of lifting point throughout a project.

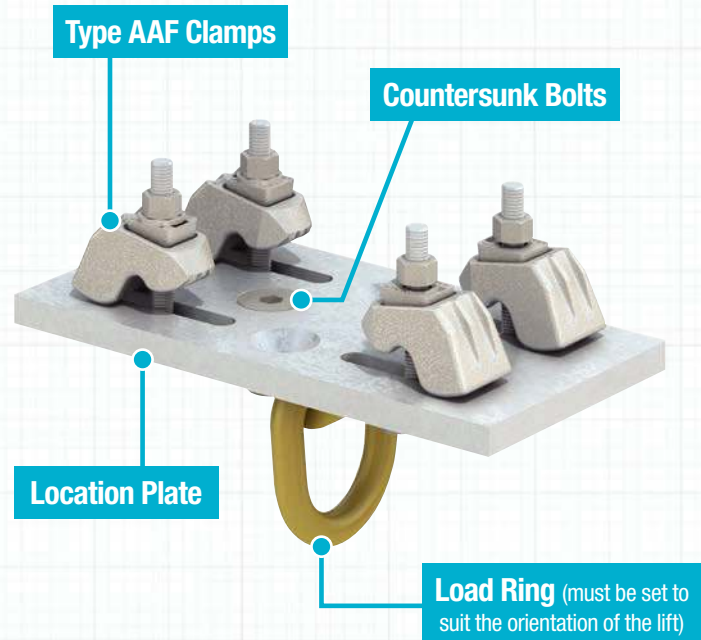

### TYPE LP

**Available with 4, 6 or 8 clamps to increase load capacity to a maximum of 200kN**

Utilising Lindapter's high strength Type AF or AAF clamps for heavy loads, the Type LP is available in bespoke configurations for large steel sections or loads up to 200kN SWL.

Whatever the application, Lindapter's durable products are valued for their quality and reliability, and provide contractors with a safe, quick and convenient lifting system.

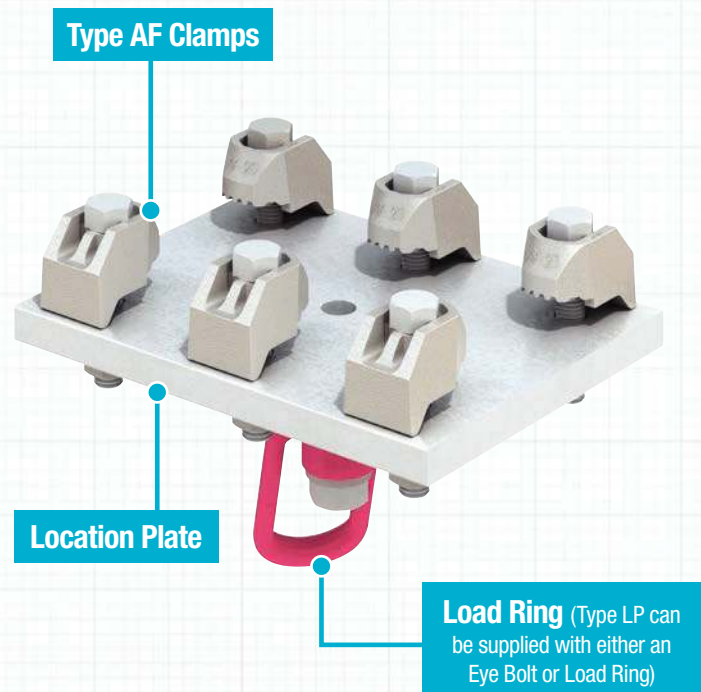

# Structural Hollow Section



**Lindapter Hollo-Bolt is an expansion bolt that only requires access to one side of the Structural Hollow Section (SHS) eliminating the need for conventional through-bolting or welding, making them ideal for oil and gas applications.**

Installation is carried out quickly and safely by inserting the product into pre-drilled holes then tightening to the recommended torque using only hand tools.

## KEY BENEFITS



- ✓ No welding or hot works
- ✓ High load capacities for heavy duty applications
- ✓ Corrosion protection to suit application

## SPOTLIGHT ON...



## Applications include:

- ✓ Primary steelwork
- ✓ Secondary steelwork
- ✓ Blast wall reinforcement
- ✓ Staircases and handrails
- ✓ Square, rectangular & circular hollow sections
- ✓ Can also be used on I beams

# Structural Hollow Section

## PROJECT EXAMPLE

### OIL FIELD PLATFORM

**Location:** North Sea offshore Norway

**Application:** Securing handrails alongside new walkways throughout the platform.

**Solution:** Lindapter Hollo-Bolt

This oil field platform is located in the Tampen area of the Norwegian North Sea and came on stream in June 2001. Engineers working on the platform wanted a method of safely securing new hand rails in various parts of the rig. Welding was deemed highly undesirable due to the inevitable disruption and possible delays that area closures would cause.

After evaluating several options, engineers specified Lindapter's Hollo-Bolt in stainless steel due to its high strength, corrosion protection and wide range of technical approvals including ICC-ES for resisting wind and seismic loads.

Contractors used brackets and size M12 Hollo-Bolts to quickly attach the hand rails to the sides of the pre-drilled steel hollow sections that support the walkways.

The Hollo-Bolt allowed contractors to safely and conveniently complete the installation process despite the restricted access to the steelwork and not being able to weld on the platform due to the fire hazards. Using standard hand tools increased the speed and simplicity of the installation which helped to achieve a fast turnaround on the project, reducing labour costs and minimising disruption.

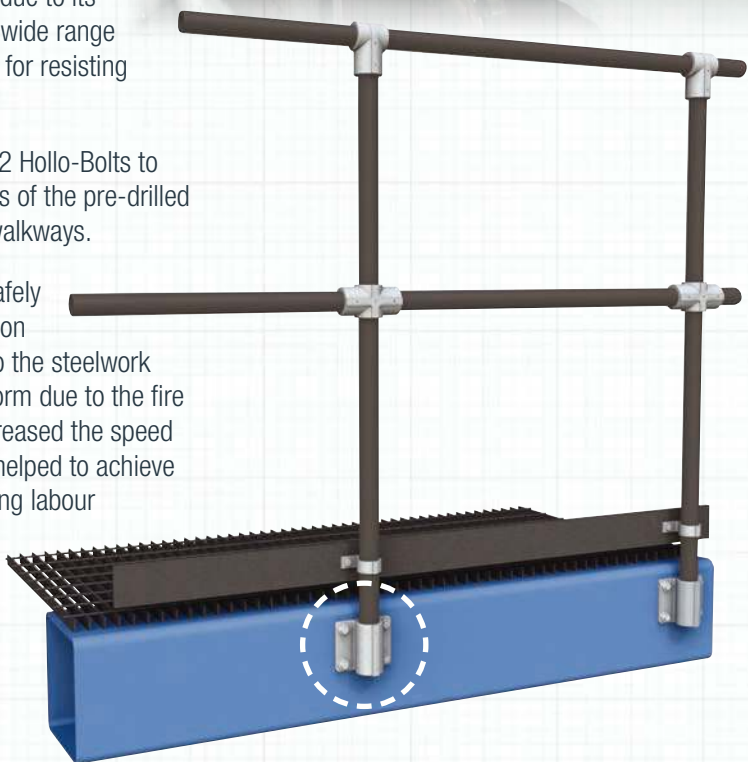
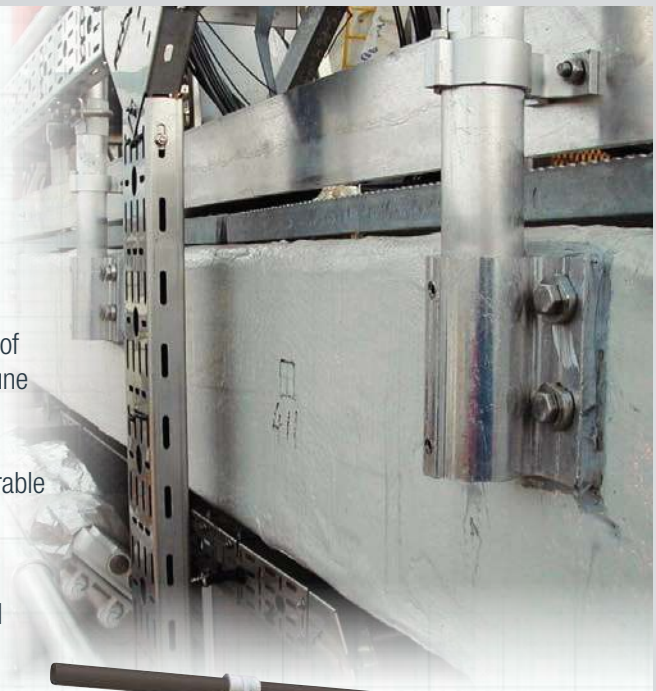

 **Hollo-Bolt™**



Read more examples of Lindapter's technical solutions on our website [www.Lindapter.com](http://www.Lindapter.com)

# Structural Hollow Section

## OTHER LINDAPTER SOLUTIONS & EXAMPLES

### STRUCTURAL CONNECTIONS

Lindapter's larger M16 and M20 Holo-Bolts are optimised for high strength structural connections and feature a High Clamping Force (HCF) mechanism for superior performance.

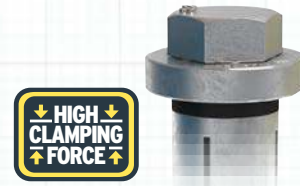

Holo-Bolt HCF are used to

**CONNECT TWO STRUCTURAL HOLLOW SECTIONS TOGETHER**

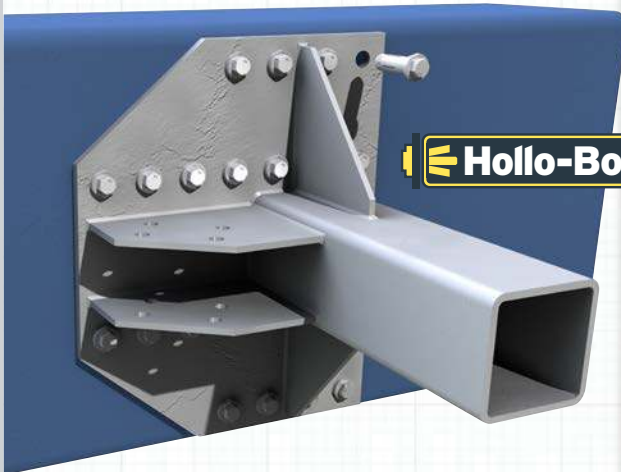

Holo-Bolt HCF are used to

**CONNECT STRUCTURAL BEAMS TO STRUCTURAL HOLLOW COLUMNS**

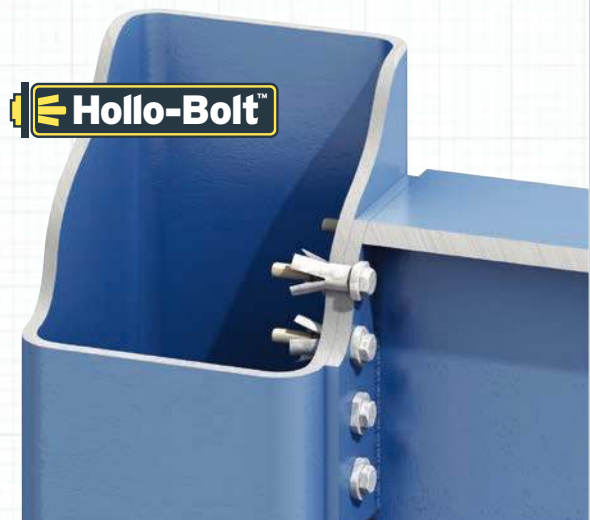

# Structural Hollow Section

## OTHER LINDAPTER SOLUTIONS & EXAMPLES

### SECONDARY CONNECTIONS

Lindapter Holo-Bolts are the ideal choice for secondary steel connections in oil and gas applications, offering a fast, cost saving installation from one side.



Hollo-Bolts are used to

**CONNECT A TUBULAR STEEL SECTION WITH END PLATE TO THE WEB OF A STEEL BEAM**

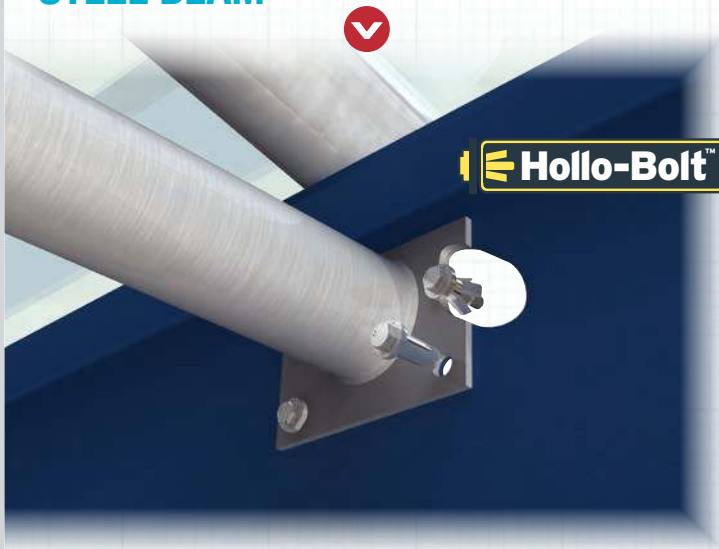

Hollo-Bolts are used to

**CONNECT A STEEL ANGLE TO THE HORIZONTAL HOLLOW SECTION**

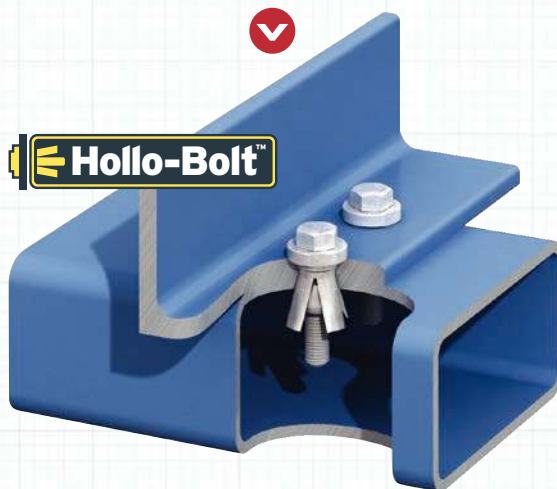

Hollo-Bolts are used to

**CONNECT A HORIZONTAL HOLLOW SECTION WITH END PLATE TO STEEL COLUMN**

# Structural Hollow Section

## OTHER LINDAPTER SOLUTIONS & EXAMPLES

### HANDRAIL

**Location:** North Rankin Oil Field, Australia

**Application:** Securing handrail to deck.

**Solution:** Lindapter Hollo-Bolt



### BLAST WALL REINFORCEMENT

**Location:** Tern Alpha Platform, North Sea, UK

**Application:** Securing a reinforcing blast wall during refurbishment of the platforms north wall.

**Solution:** Lindapter Hollo-Bolt

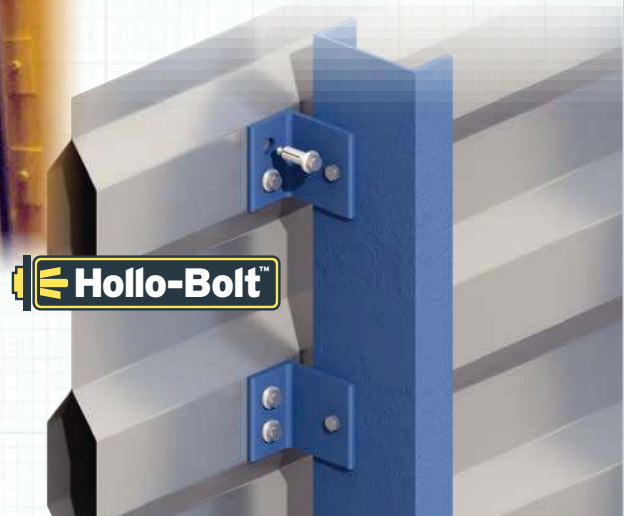

# Structural Hollow Section

## OTHER LINDAPTER SOLUTIONS & EXAMPLES

### DECOMMISSIONING

**Location:** Dunlin Alpha Platform, North Sea, UK

**Application:** Securing lifting points to circular drill sleeves for decommissioning purposes.

**Solution:** Lindapter Holo-Bolt

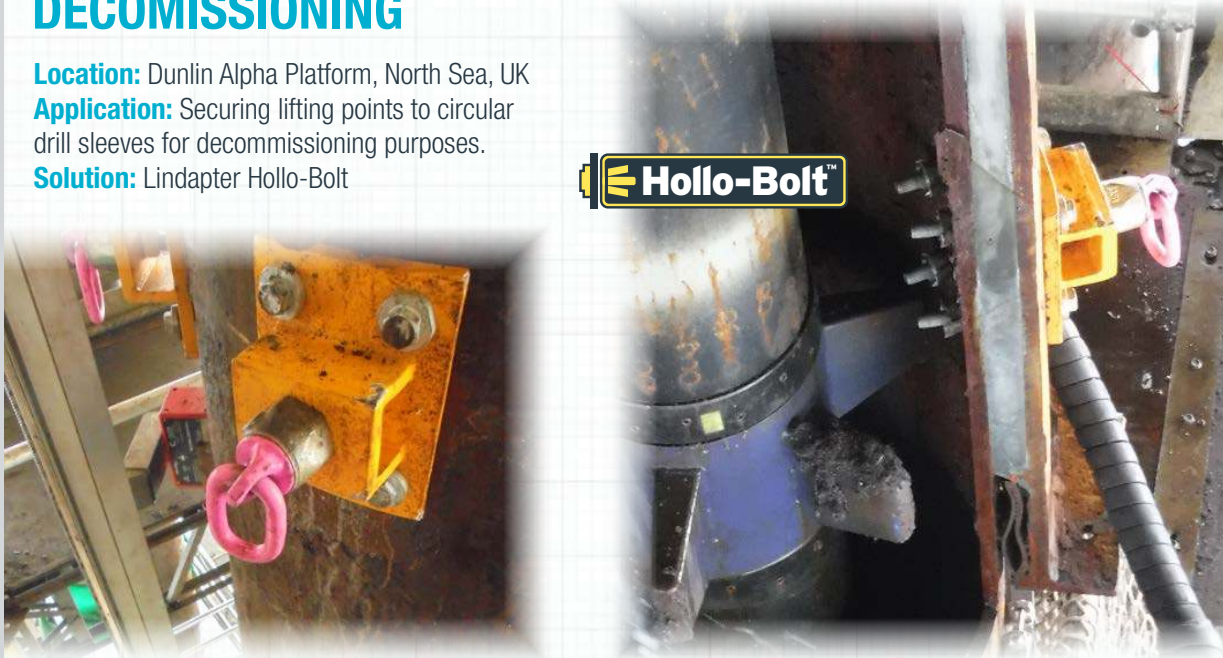

### LINDIBOLT

The Lindibolt is a self-heading bolt designed specifically for refurbishment projects for connecting steelwork to hollow sections where access is only available from one side. This unique product will fit into standard clearance holes in pre-drilled steelwork and can be adjusted during installation to fit various thicknesses of steelwork.



### PIPE SUPPORTS

**Location:** Britannia Platform, North Sea, UK

**Application:** Securing light duty pipe supports to existing SHS.

**Solution:** Lindapter Lindibolt

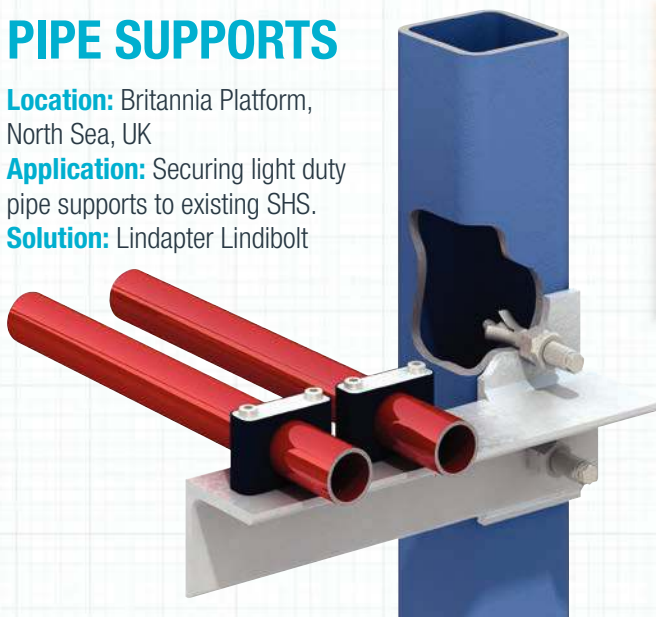

### SUBSEA

**Location:** Gibraltar

**Application:** Diver secures steel plates to the hull of a sunken ship to plug old rivet holes in subsea salvage.

**Solution:** Lindapter Lindibolt

# Steel Flooring & Grating



**Lindapter's range of innovative floor fixings for securing chequer plate flooring and open bar grating to the supporting steelwork without the need for onsite drilling or welding.**

Access to the underside of the flooring is not required, eliminating the need for costly scaffolding or elevated floors. Installation can be carried out quickly and safely from above, often by one person, significantly reducing costs.

## KEY BENEFITS



- ✓ Installation required from topside only
- ✓ Safe and quick installation
- ✓ No drilling or welding
- ✓ High corrosion resistance
- ✓ High quality and high strength

## SPOTLIGHT ON...



## Topside Installation

Lindapter steel floor fixings are all designed to only require installation from the topside. This is a significant benefit in terms of cost and safety for oil and gas projects where access from underneath would be very difficult and dangerous.

# Steel Flooring & Grating

## PRODUCT RANGE

### FLOORFAST®

Securing chequer plate flooring to supporting steelwork can be carried out quickly and safely from above, often by one person, significantly reducing costs. The stepped clamping face locks under the steelwork to provide a secure connection.

- ✓ Superior clamping force from the cast body
- ✓ Lloyd's Register Type Approval for resistance to shock and vibration
- ✓ Zero protrusion above of the floor plate surface
- ✓ Easy to remove for maintenance access
- ✓ Available in malleable iron or stainless steel grade 316

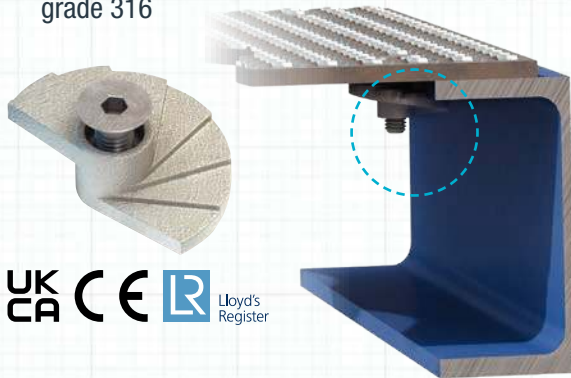

### GRATE-FAST®

A high strength floor fixing for rectangular open bar grating, providing superior clamping force due to a malleable iron cast body. Lloyd's Register Type Approval for resistance to shock and vibration.

- ✓ High-strength cast body
- ✓ Lloyd's Register Type Approved
- ✓ Fits a wide range of beams and grating
- ✓ Hot dip galvanised



### NEW HOLLO-GRATE-FAST

Leveraging the high strength of the legendary Hollo-Bolt with the ease and convenience of the Grate-Fast, the Hollo-Grate-Fast quickly secures open bar grating to Structural Hollow Section (SHS). Developed specifically for the most common sized 19-W grating, our newest innovation allows grating to be connected to SHS without drilling, welding or powder actuated fastening on site.

- ✓ High strength connection for 19-W grating to SHS
- ✓ Fast, one-sided, cost-effective installation
- ✓ No hot work permits required
- ✓ Hot dip galvanised corrosion resistance
- ✓ Easy to install from above with standard hand tools



### TYPE 1055

This unique solution enables solid steel plate flooring to be installed over the top of existing open-mesh or open-grid flooring using simple hand tools. Retrofitting pedestrian walkways on oil and gas platforms in this way is also a fire safety solution, in case of a fire the solid steel plate flooring acts as a barrier to flames.

- ✓ Fast installation from above
- ✓ Stainless steel for high corrosion resistance
- ✓ Superior clamping force from high quality castings
- ✓ Safely retrofit without welding

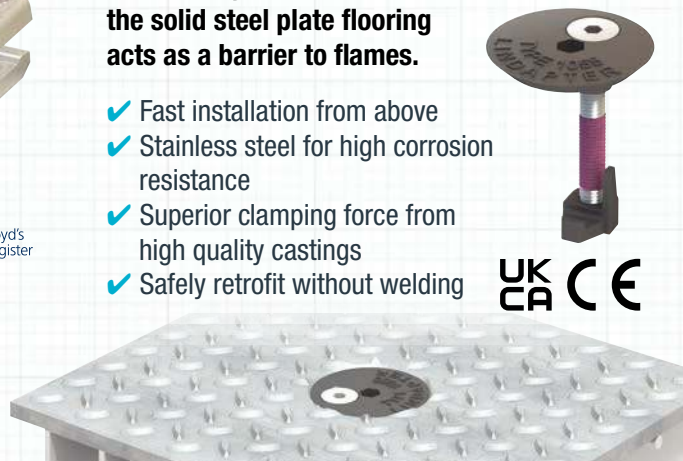

# Project Experience

## OFFSHORE

Location	Project Name	End User	Consultant/Contractor	Application	Product
Angola	Kizomba Gas Gathering	ExxonMobil	AMEC Paragon	Tray Supports & Ins Supports	LR, GF
Australia	North Rankin Platform	Woodside	Woodside	Handrail Support	HB
Australia	North West Shelf Development Project	Bhp Billiton	Woodside Energy	Cable Tray Supports	A
Australia	North West Shelf Development Project	Bhp Billiton	Woodside Energy	Platform Mounted Lighting	LR
Brunei	Brunei Liquefied Natural Gas Jetty	Minconsult	Sahid Sendirian	GC (Special)	A, B, BR, HB
Canada	Terra Nova Platform	Petro-Canada	PSN Services	Structural Hollow Section	HB, GF
Canada	Hibernia Topsides, Grand Bank	Hibernia	KBR	Structural Hollow Section	HB
Ivory Coast	Marlin Platform	Occidental Petroleum	W-Industries	Pipe Supports	AAF
Malaysia	Sarawak Shell Berhad - M1 Expansion	Shell	Technip-Coflexip	Temporary Platform Expansion	GC
Malaysia	Talisman BKA Platform	Talisman	Talisman	Pipe Supports	A, LR
Malaysia	Bongkot Fields	PTTEP	PTTEP	Pipe Supports	LR
Malaysia	Malaysia Platform Crane Installation	Various	Favelle Favco	Monorails - Offshore Cranes	A, B
Norway	Eldfisk Modification Project	Phillips Petroleum	KBR	Steelwork Connection	A, B
Norway	Froy Tie In	Pertra/DNO	Aker Offshore Partnership	Steelwork Connection	A, B, F9, LB
Norway	Gullfaks 'A' Modifications	Statoil	Kværner Installasjon	Steelwork Connection	A, B, LB, HB
Norway	Gullfaks 'C'	Statoil	HMV	Steelwork Connection	A, B, LR
Norway	Norge Shell Troll Kollsnes Topsides	Shell	Kværner Engineering	Steelwork Connection	A, B, LR
Norway	Oseberg 'A' and 'B'	StatoilHydro	HMV	Steelwork Connection	A, B, LR
Norway	Oseberg Øst-EPC Topside	StatoilHydro	Kværner Engineering	Structural Hollow Section	HB
Norway	Sleipner 'A' Platform	Statoil	ABB Offshore Technology	Runway Beam	AF
Norway	Snorre 'B' Platform	Statoil	ABB Offshore Technology	Handrail Installation	HB
Norway	Rowan Viking Jack Up Rig	Rowan Companies	-	Steelwork Connection	AF
Qatar	RasGas Offshore	RasGas	J Ray McDermott	Pipe Supports	HB
Qatar	Total Qatar Petroleum	Total E&P	Dolphin Energy / Descon Engineering	Steelwork Connection	AAF
Saudi Arabia	Karan Offshore Subsea Project	Saudi Armaco	J Ray McDermott	Grating Fixings	GF
Trinidad	Angostura Field Development	Bhp Billiton	Worley Parsons	Pipe Supports	A
Trinidad	BGGT HIBISCUS	BG	Fluor	Pipe Supports	AF
Trinidad & Tobago	Ruby Brownfield	BHP	Technip Offshore Eng	Skid/Tank Mounts	AF
Tunisia	Gas Miskar Compression Unit	BG	British Gas	Cable Ladder Support	A
U.A.E	Platform Refurbishment	Petrofac	Dubai Petroleum/OIL	Riser Winch Support	LB, HB
U.A.E	Platform Refurbishment	Hurcules Drilling	Maritime Industrial Services	Recon Beacon Installation	HB
U.A.E	Falah B ESP Installation	Petrofac	Dubai Petroleum/OIL	Pipe Supports	LR, LB
UK	Piper Bravo Platform	Talisman	AMEC	Floor Fixings	FF
UK	Tern Alpha Production Platform	Shell	J. Ray McDermott	Strengthening Blast Wall	HB
UK	Eider Platform	Shell	J. Ray McDermott	Structural Hollow Section	LB
UK	Production Flowline For Wellhead 16	Shell	Shell	Pipe Supports	A
UK	Britannia Ship to Shore	Britannia Project	KCA Drilling	Pipe Supports	LB, B
UK	Shell Central FPSO Dev	Shell	Rockwater	Beam Mounted Transporter	A
UK	Condensate Pipework Replacement	Shell	Sigma3	Pipework Replacement	A, AF
UK	Auk Jubilee Project	Shell	KBR	Cable Tray Supports	B
UK	Elgin Puq	Total	Sparrows Offshore	Comp. Bundle Removal Beams	AF
UK	Maersk Giant Winch Re-locations	Maersk	Fabricom	Reloc. of B.O.P Winches	A
UK	NCP Rig Skidding Improvements	CNR	KCA Deutag	Rig Skidding Improvements	A
UK	Sarawak Shell Berhad	Shell	Samsung / Technip/KBR	Integral Deck Fixing	A
UK	Leman B Platform	AMEC	Carpenter & Paterson	Hanger Assembly	A
UK	Duba Offloading Platform	KW Consultants	PMS	Pile Template struc. & Guide Assy	AF
UK	Amoco (operated) Lomond Platform	Texaco	Kværner H & G Offshore	Steelwork Connection	GC
UK	Rough Alpha Gas Platform	Centrica	Babcock	Helideck Installation	A
UK	Aviat Gas Field	Apache North Sea Ltd	Harkand	Steelwork Connection	AF
UK	Dunlin Alpha	Fairfield Energy	Aquaterra	Decommissioning	AF, HB
UK	Heatshielding	Locker Heatshielding Ltd	-	Heat Shields	CF
UK	MeyGen Tidal Turbine	Atlantis Resources Ltd	-	Subsea Instrumentation Sled	AF
USA	Exxon/Mobil Baytown	Exxonmobil	GDS Engineers/Fluor/KBR	Pipe Supports	D2, LR
USA	BP - Mardi Gras Platform	BP	Paragon Engineering	Girder Clamps	A, B
USA	MEGI FPU Tanker	MEGI	Albert Garaudy Engineers	Pipe Supports	AF
USA	BP	BP Tanker	Albert Garaudy Engineers	Girder Clamps	A, B
USA	Exxon Heritage Platform	Exxon	Albert Garaudy Engineers	Diluent Skid & Pipe Supports	GC
USA / Gulf	Horn Mountain West	Occidental Petroleum	Wood	Pipe Supports & Lighting Mounts	AAF
USA / Gulf	Constitution Brownfield	Occidental Petroleum	Arion Blue	Pipe Supports	AAF
USA / Gulf	ConstitutionZ Facility	Occidental Petroleum	Arion Blue	Pipe Supports	AAF
USA / Gulf	Lucius Brownfield Platform	Occidental Petroleum	Wood	Pipe Supports	AAF
USA / Gulf	Marco Polo Platform	Occidental Petroleum	OFD	Pipe Supports	AAF
USA / Gulf	K2	BHP	HB Rentals	Skid Mounts	AAF
USA / Gulf	Shenzi Platform	BHP	OFD	Pipe Supports	AAF

# Project Experience

USA / Gulf	Brown & Roots	Shell	Shell	Lift Support	A
USA / Gulf	Salsa/Enchilada	Shell	Shell	Grating & Pipe Supports	1055, AAF
USA / Gulf	Thunder Horse	BP	Worley	Pipe Supports, Skid Mounts	AAF, AF
USA / Gulf	Atlantis	BP	Worley	Monorail Supports	AAF
USA / Gulf	Na Kika	BP	Worley	Hoist Rail Supports	LR
USA / Gulf	Mad Dog II	BP	Worley	Winch Mounts	A
USA / Gulf	MEDUSA Skimmer Platform	Murphy	EDG	Pipe Racks	AAF
USA / Gulf	Ballmore Topside Project	Chevron	Chevron	Pipe Supports	AAF
USA / Gulf	Boomvang Platform	OXY (Occidental Petroleum)	ArionBlue	Pipe Supports	AAF
USA / Gulf	Constitution Platform	OXY (Occidental Petroleum)	ArionBlue	Pipe Supports	AAF
USA / Gulf	Horn Mountain Platform	OXY (Occidental Petroleum)	ArionBlue	Pipe Supports	AAF
USA / Gulf	Holstein Platform	OXY (Occidental Petroleum)	ArionBlue	Pipe Supports	AAF
USA / Gulf	Lucius Platform	OXY (Occidental Petroleum)	ArionBlue	Pipe Supports	AAF
USA / Gulf	Marlin Platform	OXY (Occidental Petroleum)	ArionBlue	Pipe Supports	AAF
USA / Gulf	Stampede Platform	Hess	ArionBlue	Pipe Supports	AAF

## ONSHORE

Location	Project Name	End User	Consultant/Contractor	Application	Product
Brazil	Degussa Chemical Plant	Degussa Chemicals	Bragussa Quimicos	Steelwork Connection	LR
Brazil	Petroquímica Suape	Petrobras Química S.A.	Odebrecht	Cable Tray Support	A
Brunei	Brunei Shell Petroleum	Shell	Kenwil Electrical	Conduit Support	F3
Brunei	Brunei Shell Petroleum Loading Pier	Shell	Steen Sehested & Ptrs	New Loading Jetty	A, B
Canada	Land Rig Refurbishments	Various	Nabors Drilling	Pipe Supports	A, B
China	Daya Bay Nuclear Power Station, Canton	CLP	GEC Alsthom	Steelwork Connection	GC, FL
China	Shajiao 'C' Power Station	ALSTOM	Ove Arup & Partners	Support Fixing	F3, FL, LC
China	Phu My 2 Phase1 Extension Addon Plant	EVN	PECC3/Colonco/Fichtner	Cable Tray Supports	AF
Finland	Kaverer Recovery Boiler	BURGORB	Aker Kvaerner	Pipe Supports	LR
Hong Kong	CL & P Black Point Power Station 'C'	CLP	Mouchel Asia	Steelwork Connection	GC, FL, LR
Hong Kong	CL & P Tap Shek Kok Power Station	CLP	Mouchel Asia	Steelwork Connection	GC, FL, LR
Iceland	Fjarðal Smelter Project	ALCOA	Bechtel	Pipe Supports	AF, A, HW
Ireland	Shell Corrib Gas Processing Terminal	Shell	SIAC Butler	Grating	GF
Kazakhstan	KTL Expansion Project, Enka, Tengiz	Bechtel-BE JV	Bechtel-BE JV	Steelwork Connection	A, C1
Kuwait	Sabiya Power Station	Sabiya Power Station	Hyundai Eng., Richard Lees	Services Support	A, AW
Malaysia	Jana Manjung Power Station	Jana Manjung	Alstom USA	Flooring	FF
Malaysia	Kikeh Project Dry Tree Unit	Petronas	Ranhill Worley	Pipe Supports	LR
Oman	Manah Power Station	United Power Co.	AMEC Power	Support Fixing	F3, A
Qatar	QAPCO Fertilizer Plant	QAPCO	Thyssen Krup	Flooring	FF
Qatar	QATALUM	QATALUM	K Holm International	Support Fixing	HC, HW
Qatar	RasGas Onshore Operations	RasGas	RasGas Maintenance	Valve Lifting Beams	AF
Saudi Arabia	Saudi Kayan Petrochemical	RasGas	Fluor	Pipe Supports	F9
Saudi Arabia	Saudi Kayan Petrochemical	RasGas	KBR	Radiant Section	HC, HW
Singapore	Shell Eastern Petroleum – Ethylene Cracker	Shell	Toyo Engineering	Pipe Supports	A
U.A.E	Jebel Ali Condensate Refinery	ENOC	Larsen & Toubro	Pipe Supports	B
U.A.E	Aweer Gas Turbine Power Station, Dubai	AWEER	Mitsubishi Heavy Industries	Steelwork Connection	D2, F3
U.A.E	Escravos Gas to Liquid Nigeria	KBR/Chevron	Gulf Piping	Pipe Supports	LR, F9
U.A.E	Borouge Ethylene Plant	Borouge	UTS Kent	Pipe Supports	A, LR
U.A.E	DUBAL	DUBAL	Belleli Energy	Plant Expansion	A
U.A.E	DUBAL	DUBAL	DUBAL Maintenance Team	Conveyor Support	HC, HW
U.A.E	Integrated Gas Development (IGD)	GASCO	UTS Kentz	Cable Ladder Supports	A, B
U.A.E	BP Sharjah - LPG Access Tower Repair	BP Sharjah	MIS	Tank Support	LR
UK	BNFL Sellafield Re-Processing Plant	BNFL	Wormald/AMEC	Flooring	FF, HB
UK	Drax Power Station Gas De-Sulphurisation	Drax	Darchem	Cable Tray Supports	GC
UK	Exxon Chemical Olefins	Exxon Mobile/ ABB	AMEC	Steelwork Connection	FF, A, B, D2
UK	Bacton Gas Terminal	Shell	Technicus Consulting/Munnings Construction	Roof Replacement	CF, AF
USA	Distrigas LNG Facility	Suez	Fluor	Stair Tower	GC
USA	DuPont Victoria	DuPont Victoria	Fluor Daniel	Steelwork Connection	A, B
USA	Shell Narco	Shell Narco	Jacobs Engineering	Pipe Supports	B
USA	Shell Deer Park	Shell Deer Park	S & B Engineers	Pipe Supports	A, B
USA	Valero	Valero	Fluor Corp.	Monorail	GC
USA	DuPontt Chemical	DuPontt Chemical	Ford, Bacon & Davis	Flooring	GF
USA	Baytown Texas Refinery	Exxon Mobil	-	Pipe Supports	LR
USA	Heidelberg Facility	Occidental Petroleum	Arion Blue	Skid Mounts	AAF
USA	Wilmington, CA Refinery	Phillips 66	AltairStrickland	Pipe Supports	AAF
Vietnam	Phu My 1 Combined Cycle Power Project	Mitsubishi Heavy Ind.	Sanyo Engineering & Cons.	Steelwork Connection	A, CW

# Technical Support & Service

## WE ARE HERE TO HELP

Lindapter offers an extensive range of technical support and services to help you achieve the optimum solution for your next project or application. Our philosophy is to deliver the highest level of service from initial design through to installation guidance.

### ONLINE GIRDER CLAMP CONFIGURATOR

Lindapter's new online design tool for engineers and specifiers produces fully detailed connection drawings within seconds. Find your next solution at [www.Lindapter.com](http://www.Lindapter.com)

### FREE CONNECTION DETAILING

Lindapter can design a bespoke connection based on your specific requirements free of charge.

Our Technical Support Engineers will supply customised CAD drawings and BIM compatible files to complement your designs.

### CHARACTERISTIC RESISTANCES

When designing a connection to Eurocode 3 please refer to our Declaration of Performance certificates that are available to download from [www.Lindapter.com](http://www.Lindapter.com). For applications with unusual loadings or where dynamic conditions are present contact Lindapter technical support.



# Accreditation & Approvals

## INDEPENDENT PRODUCT APPROVALS



### CE Mark

Provides additional assurance that a product complies with the EU Construction Product Regulation and will perform as stated in the corresponding Declaration of Performance (DoP). DoPs list Characteristic Resistances for use when designing connections to Eurocode 3.



### UKCA

Demonstrates compliance with the Construction Products Regulation in Great Britain. Independently verified product specification data, including Characteristic Resistances for designing connections to Eurocode 3 are published in Declaration of Conformity (DoC) documents.



### Fire Ratings

As part of our continued commitment and investment in product development, many Lindapter products are independently fire tested in accordance with BS EN 1991-1-2.



### Factory Mutual

This American insurance organisation offers an approval that is recognised by the fire protection industry worldwide.



### VdS Schadenverhütung GmbH

VdS is a leading independent testing institution in Germany for products used in fire protection applications.



### ICC-ES

North America's leading evaluation service has approved multiple Lindapter products to be compliant with the International Building Code.



### Dynamic Load Approval

Lindapter has gained independent ETA / CE Mark approval for Types A, B, AF and AAF when used in dynamic load applications.



### Lloyd's Register Type Approval

Products subjected to tensile, frictional, vibration and shock tests, witnessed and verified by Lloyd's Register.



### TÜV Nord

TÜV is the certifying authority for safety, quality and environmental protection in Germany.

## QUALITY, ENVIRONMENT & TRACEABILITY

Accredited to **ISO 9001** since 1986, Lindapter strictly enforces a quality management system that includes rigorous product testing to ensure consistently high manufacturing standards. As part of Lindapter's ISO 9001 quality management system and in compliance with the Construction Products Regulation, Lindapter operates a comprehensive Factory Production Control system that ensures traceability of all Lindapter products throughout the manufacturing process.



The company also operates an **ISO 14001** certified environmental management system, constantly monitoring and improving aspects of the business that may impact on the environment, such as the use of natural resources as well as handling and treatment of waste and energy consumption.



**Disclaimer** Lindapter International supplies components in good faith, on the assumption that customers fully understand the loadings, safety factors and physical parameters of the products involved. Customers or users who are unaware or unsure of any details should refer to Lindapter International before use. Responsibility for loss, damage, or other consequences of misuse cannot be accepted. Lindapter makes every effort to ensure that technical specifications and other product descriptions are correct. 'Specification' shall mean the specification (relating to the use of the materials) set out in the quotation given by the Seller to the Buyer. Responsibility for errors or omissions cannot be accepted. All dimensions stated are subject to production tolerances - if in doubt please check with Lindapter. In the interests of improving the quality and performance of Lindapter products, we reserve the right to make specification changes without prior notice.

© Lindapter International 2025 LINDAPTER is a registered trademark. Lindapter may also have trademark rights in other terms used herein.



# **lindapter**<sup>®</sup>

Ask Lindapter to design a solution  
to your connection requirements:

**Tel:** +44 (0) 1274 521 444

**General Enquiries:** [enquiries@Lindapter.com](mailto:enquiries@Lindapter.com)

**Technical Support:** [support@Lindapter.com](mailto:support@Lindapter.com)

