

Façades & Cladding

lindapter

Technical Innovation in
Steelwork Connections

 MAURIN FIXATION

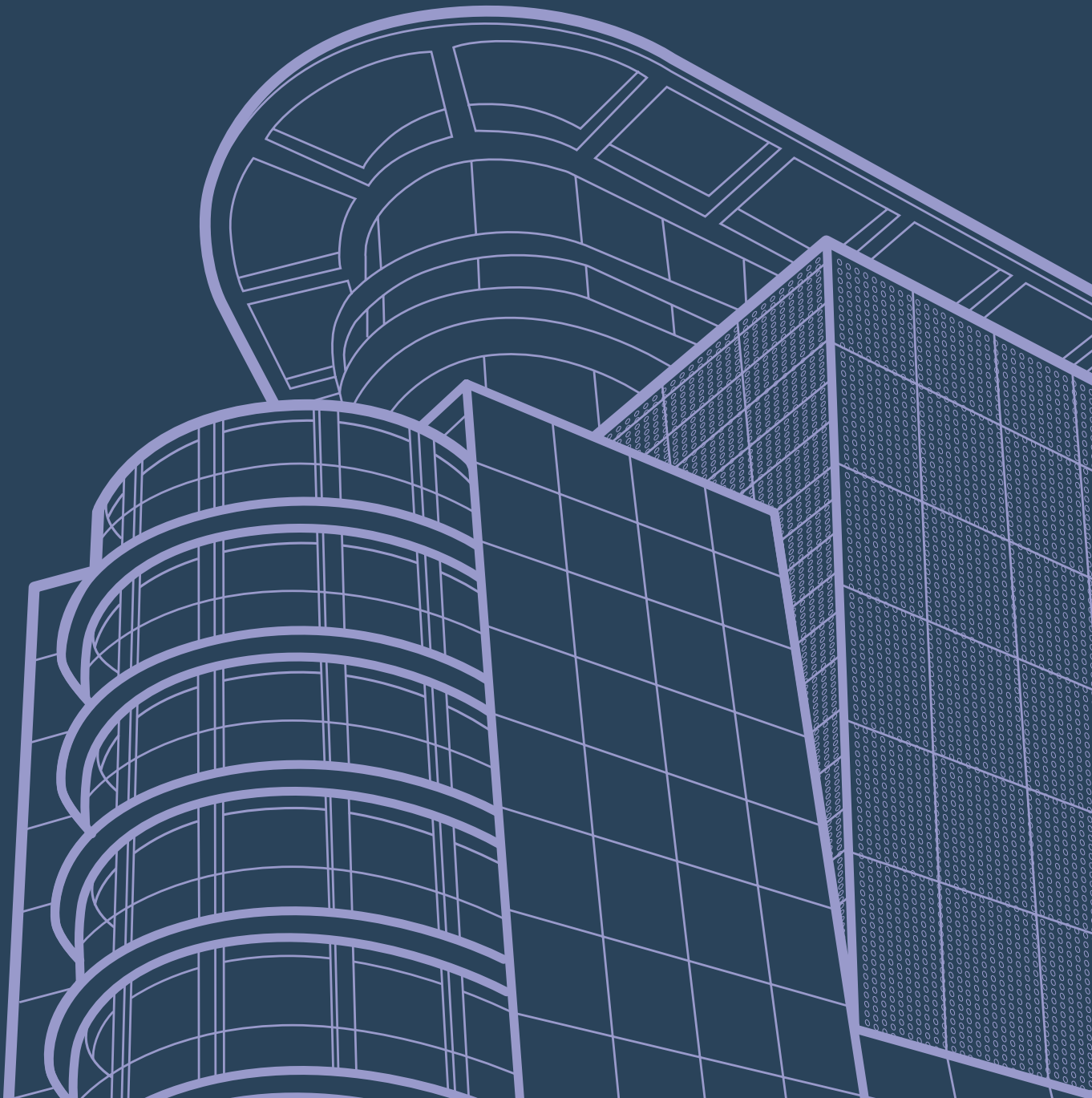

Lindapter – Safely securing steelwork for over 75 years

Established in 1934, Lindapter builds upon its proud history of developing innovative steel connections and applies their proven clamping concept to the building envelope. Today, Lindapter products are used around the world to connect a wide range of façade materials to various types of structures including:

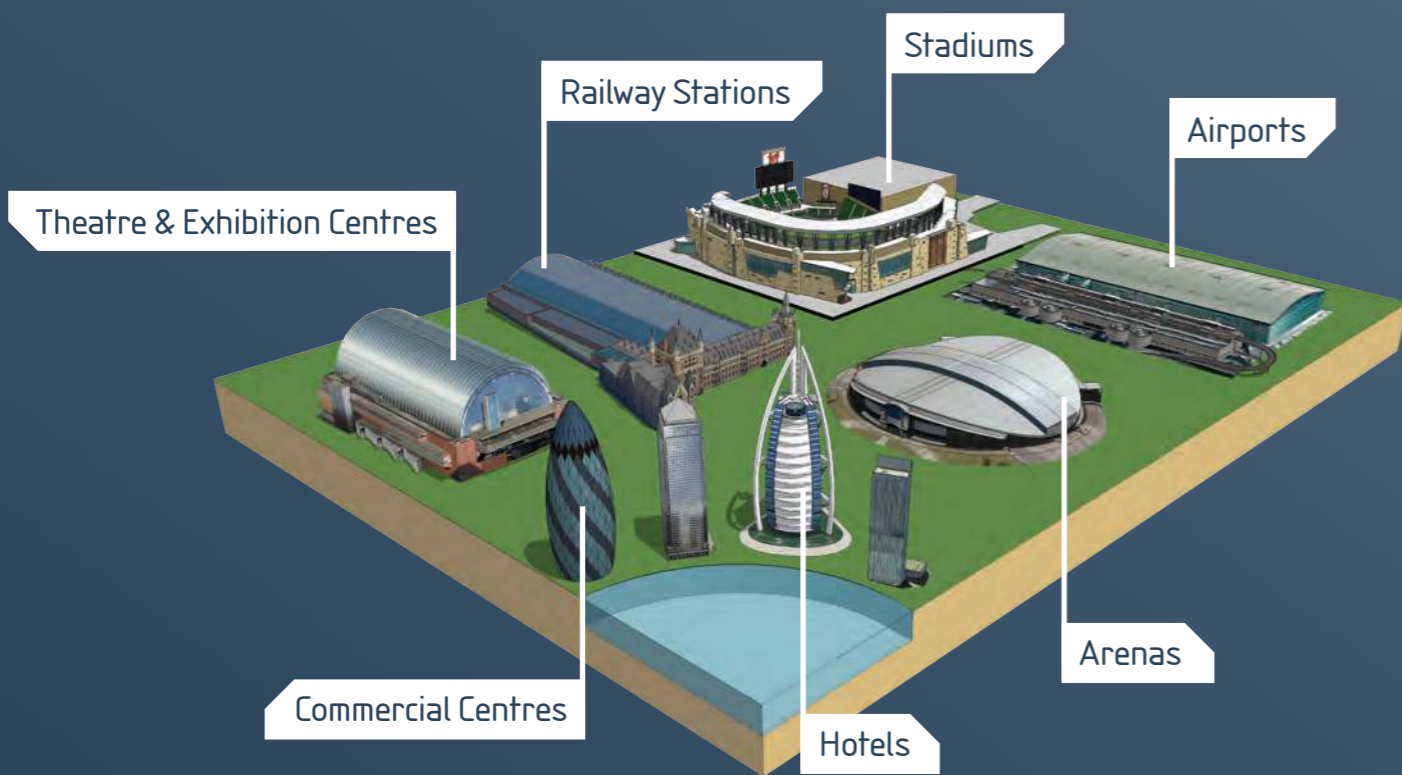

Contents

- Structural Steel Frames 4
- Structural Hollow Section 14
- Steelwork Connections 20
- Project Experience 24
- Project Case Study 25
- Approvals 26
- Technical Support 27

Whether securing precast concrete panels, glazing frames, GRC cladding or other architectural façades, Lindapter has a proven connection solution.

As the inventor and innovator of steelwork clamping systems, Lindapter's extensive experience and wide range of products are perfectly suited to fixing elements of a building exterior to the structural steel frame.

The fundamental benefit of a Lindapter connection is the speed and ease of installation, thus reducing the cost of labour and equipment hire. As drilling or welding is not required, potential safety risks are also reduced.

This brochure provides examples of cladding fixing assemblies, designed for permanent applications. Please contact Lindapter to discuss your connection requirement.

Disclaimer

Lindapter International supplies components in good faith, on the assumption that customers fully understand the loadings, safety factors and physical parameters of the products involved. Customers or users who are unaware or unsure of any details should refer to Lindapter International before use. Responsibility for loss, damage, or other consequences of mis-use cannot be accepted. Lindapter makes every effort to ensure that technical specifications and other product descriptions are correct. 'Specification' shall mean the specification (relating to the use of the materials) set out in the quotation given by the Seller to the Buyer. Responsibility for errors or omissions cannot be accepted. All dimensions stated are subject to production tolerances – if in doubt please check with Lindapter.

© Lindapter 2011 © Lindapter International
 © Lindapter is a registered trade mark
 In the interests of improving the quality and performance of Lindapter products, we reserve the right to make specification changes without prior notice.

Comprehensive technical support from Lindapter's experienced engineers includes a free connection design service to assist façade engineers through an efficient specification process, and extends to contractors with site visits (upon request) and installation advice. The Lindapter design and support service includes:

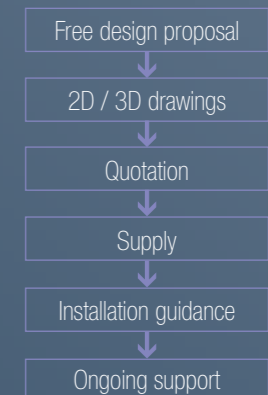

10 Reasons to use Lindapter connections

- Faster installation, lower labour costs
- Suitable for standard beams or hollow section
- No drilling or welding on-site
- On-site adjustability for accurate positioning
- Compatible with a wide range of brackets
- Can be pre-assembled to minimise installation time
- No damage to steelwork or panels
- Only standard hand tools required
- Independently approved safe working loads
- Available in a range of materials and protective coatings

Online Support

- Innovative 'Assembly Selector' tool (identifies a solution based on your requirements)
- CAD Downloads
- Product specification data
- Case studies and approvals
- Distributor contact information
- Download or request a copy of Lindapter's catalogue



Structural Steel Frames



Hot rolled structural sections are manufactured with inevitable variations in exact dimensions, while steel erection techniques will create unavoidable tolerances in straightness along beam length and other dimensions. Accurate adjustability during installation is therefore an essential prerequisite of the cladding support system.

Lindapter facilitates this requirement with convenience, allowing the cladding contractor to simply slide the bracket or other fixing assembly along a vertical or horizontal structural beam with precise alignment, before tightening the Lindapter components with a torque wrench. This method enables the rapid installation of large areas of cladding and significantly reduces the period of crane operation.

The following pages provide examples of connecting façade panels to structural sections. The illustrations highlight the many possibilities of securing panel brackets and threaded bar fixing assemblies. Please feel free to contact Lindapter's Technical Support Department to discuss your specific connection requirement.

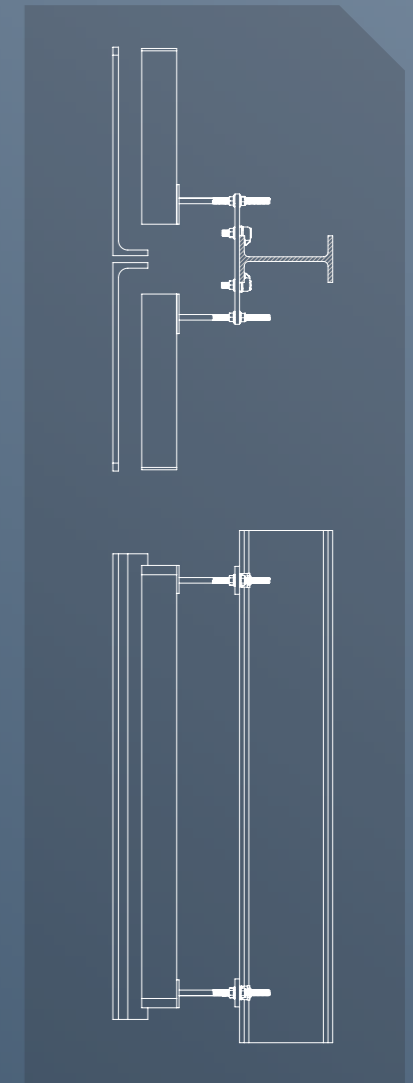
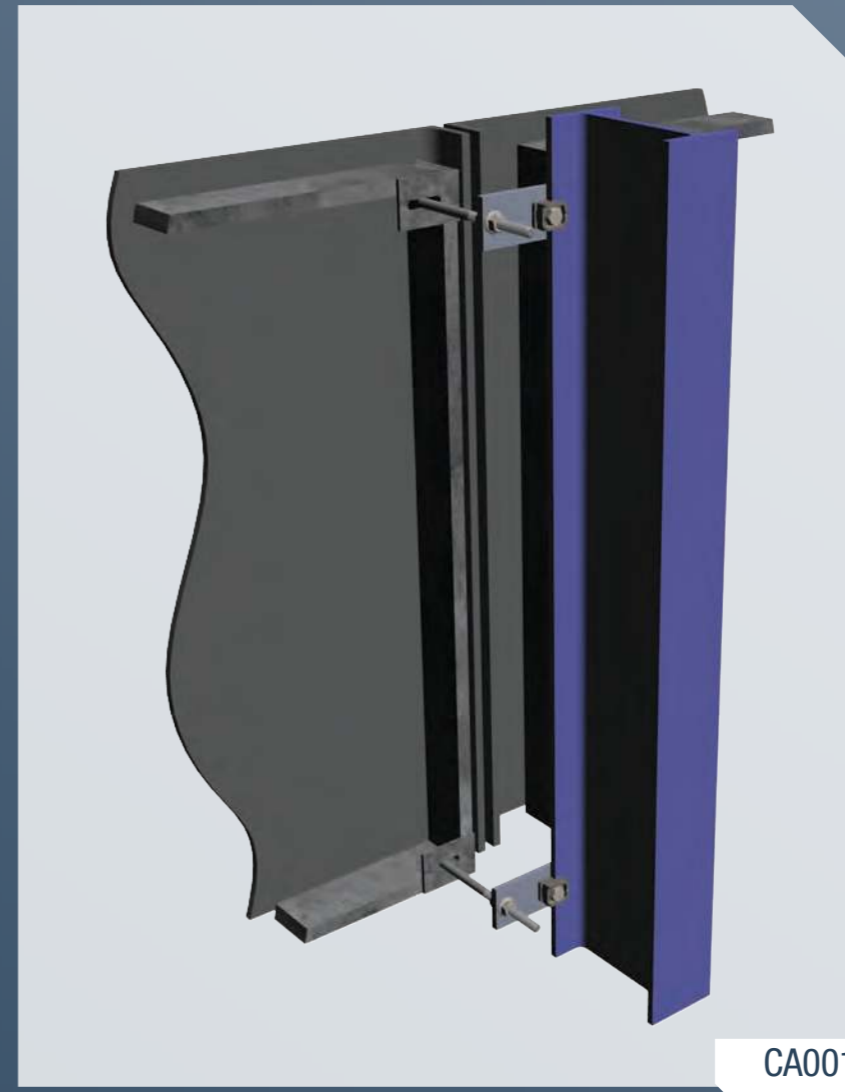

CA001

Lindapter Type A clamps connect the stud frame of glass reinforced concrete (GRC) panels to structural steel. The Type A holds the bolt head captive during tightening of the nut for ease of installation. The clamping arrangement allows vertical and horizontal adjustment of the panels on-site.



The fixing assembly above is reproduced from the 'Practical Design Guide for Glass Reinforced Concrete' published by the International Glassfibre Reinforced Concrete Association (GRCA). The guide is available from the GRCA website: www.grca.org.uk/publications.

Recommended products:



Type A Type B Type LR Type AF Type CF Type LS

Please refer to the Lindapter catalogue or website for full product data

Structural Steel Frames



CA002

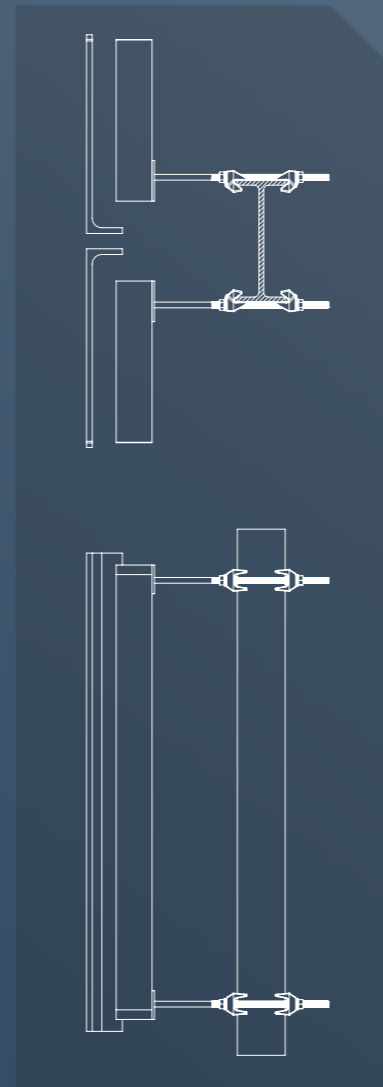

Type CF high friction clamps hook around the flanges of the vertical steel section to secure the stud frame of GRC panels. The fixing assembly allows vertical and horizontal adjustment of the panels on-site.



The fixing assembly above is reproduced from the 'Practical Design Guide for Glass Reinforced Concrete' published by the the International Glassfibre Reinforced Concrete Association (GRCA). The guide is available from the GRCA website: www.grca.org.uk/publications.

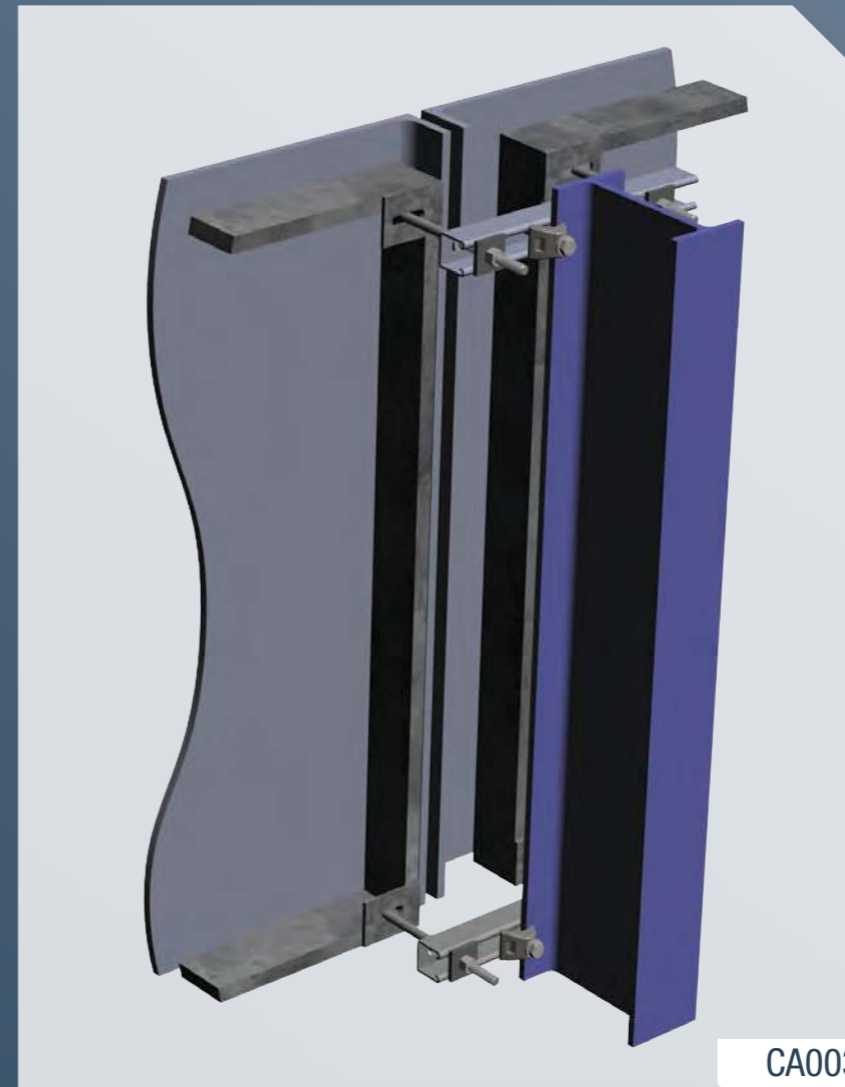

CA003

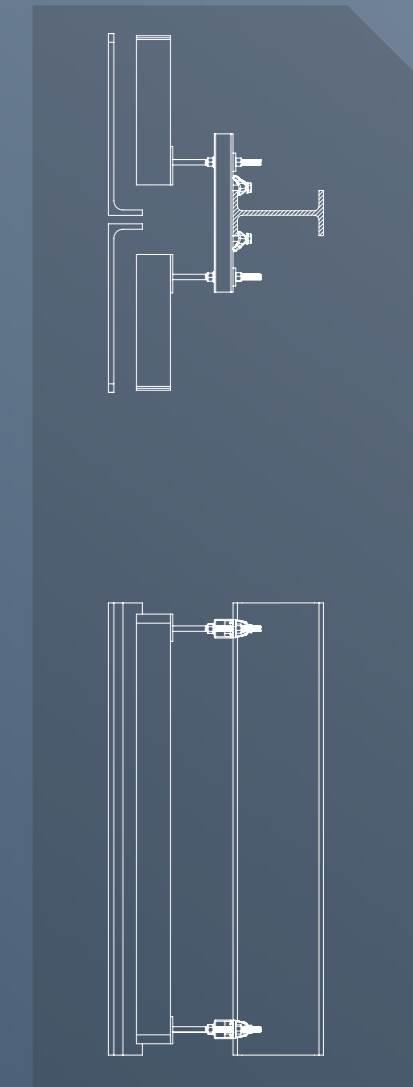

Lindapter's stainless steel Type LS secures a metal framing section in a friction application. The clamp is self-adjustable, allowing a single product to fit various beam thicknesses, with the tail spanning the recess of the strut to maximise the clamping range. The fixing configuration facilitates adjustability on three axes.



The fixing assembly above is reproduced from the 'Practical Design Guide for Glass Reinforced Concrete' published by the the International Glassfibre Reinforced Concrete Association (GRCA). The guide is available from the GRCA website: www.grca.org.uk/publications.

Structural Steel Frames

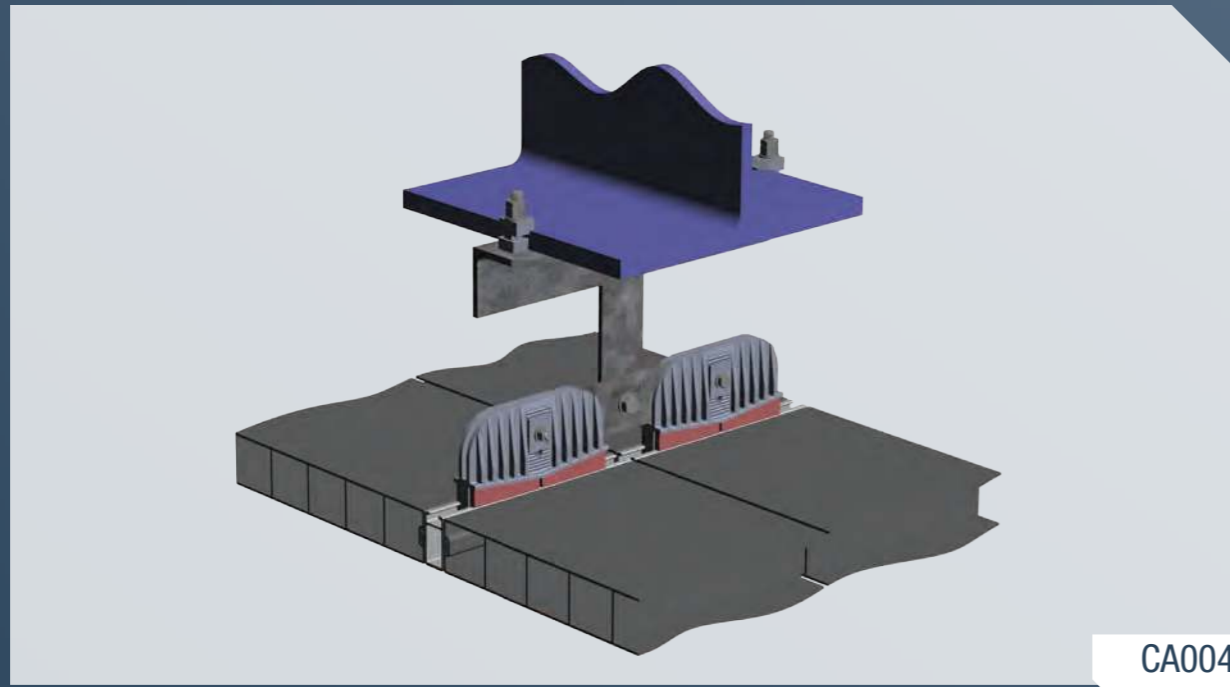

CA004

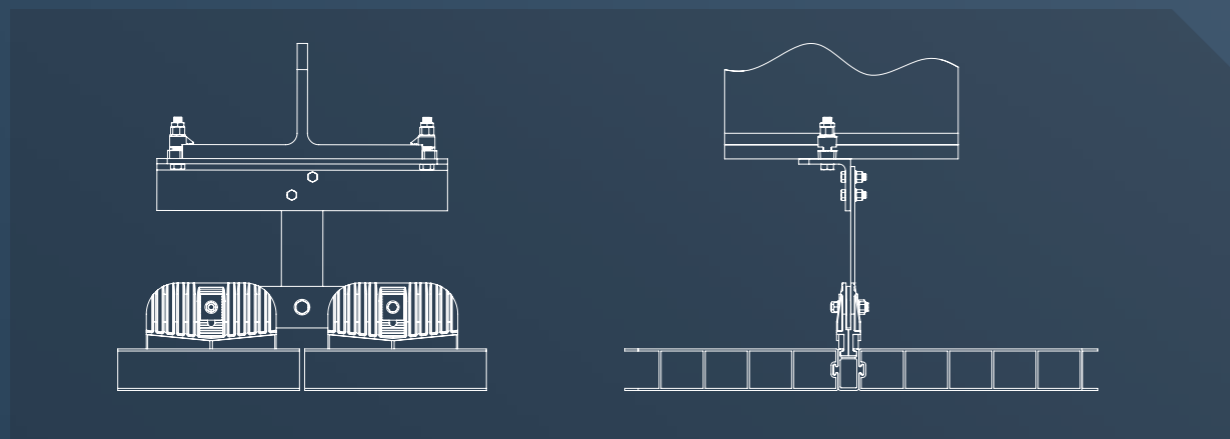

A GRP enclosure system is suspended below a bridge soffit using Type B fixings. The connection simplifies lateral adjustment along the supporting steelwork.

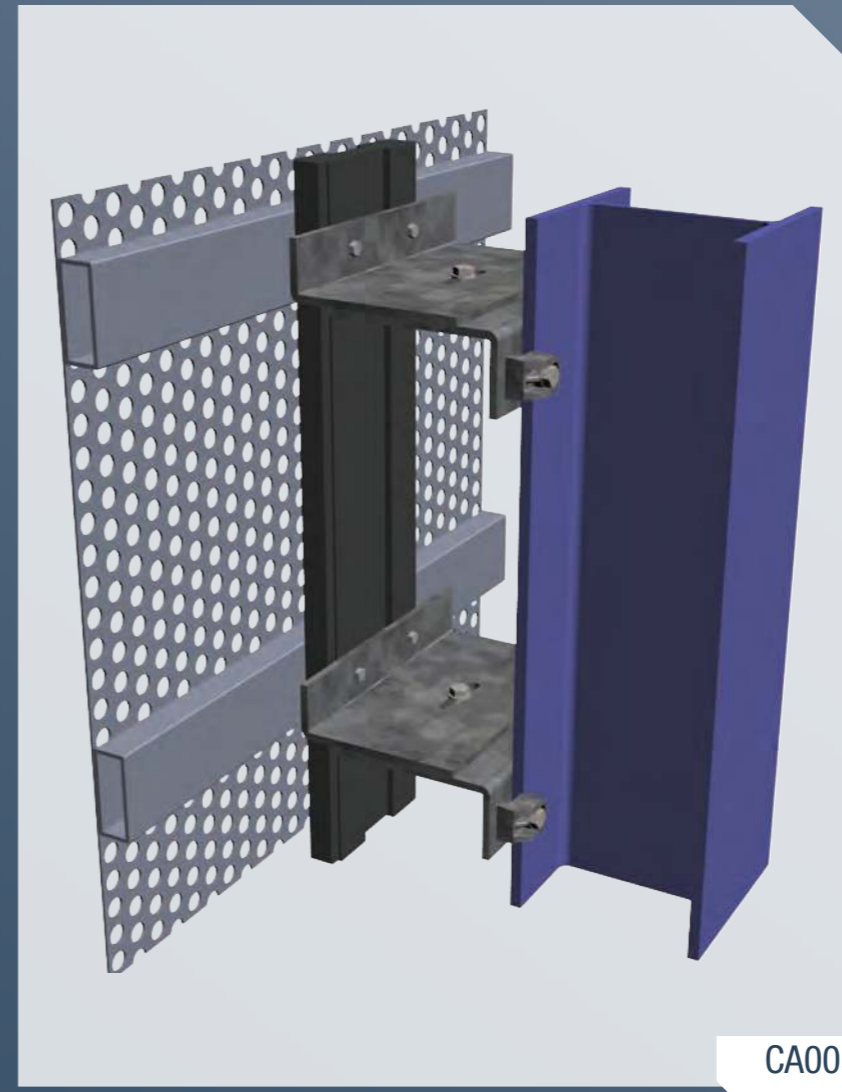

CA005

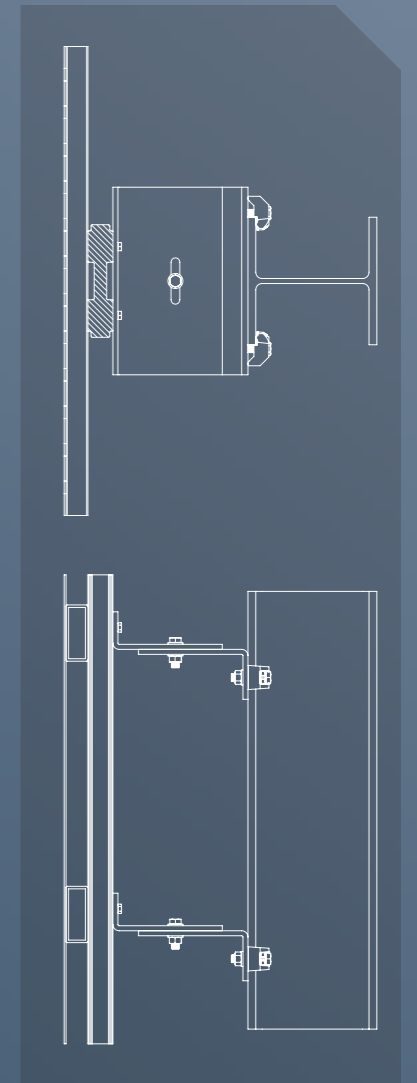

Lindapter's high performance Type AF connects the framework of perforated steel cladding to vertical columns. The bracket arrangement allows vertical and lateral adjustment. The Type AF performs excellently in friction applications. Please refer to the Lindapter catalogue for product specification data including safe working loads.

Structural Steel Frames

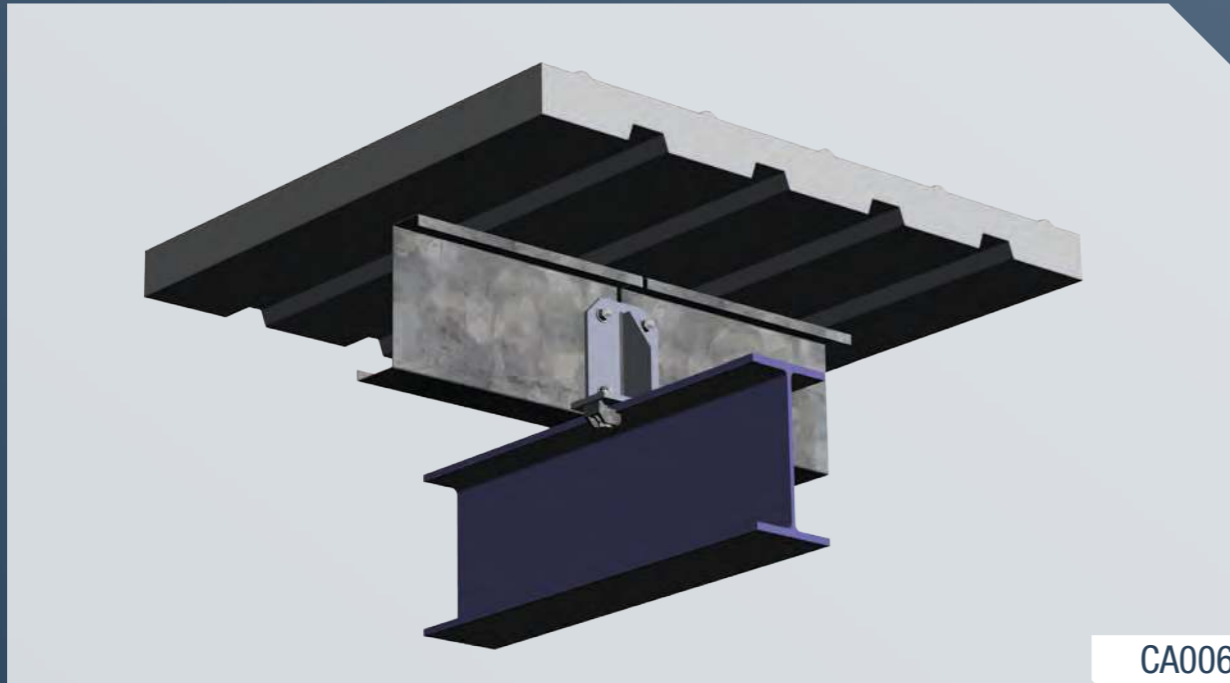

CA006



CA007

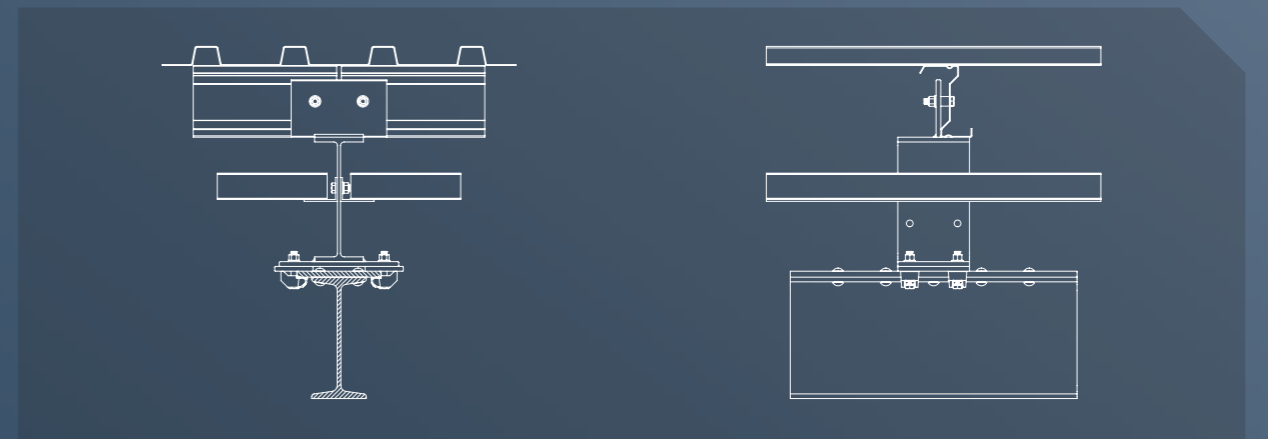
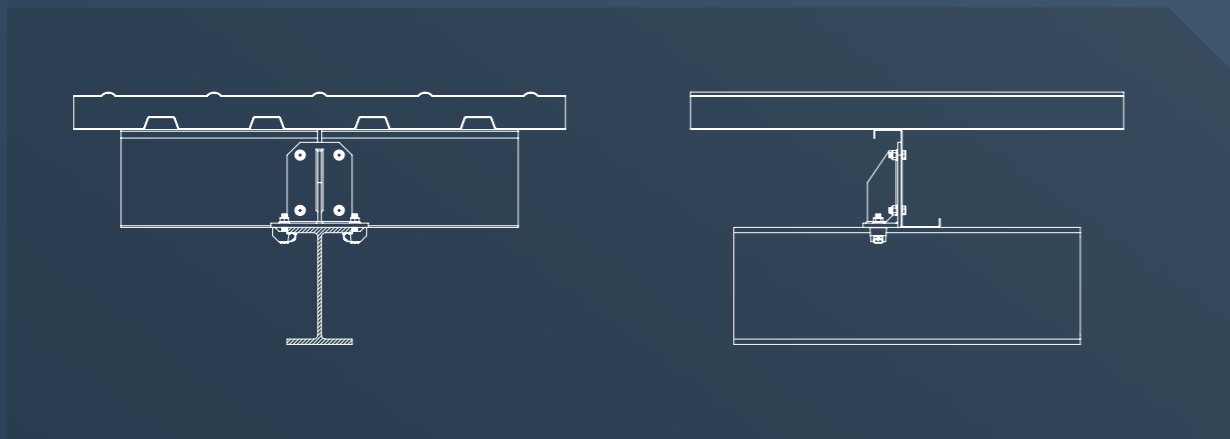

Roofing support cleats connected to a structural steel frame. The adjustable arrangement allows accurate positioning of the purlins.

Lindapter's Type AF, as specified to connect roofing supports to an existing structural frame. The fixing system permits lateral adjustment during installation and provides a high frictional safe working load.

Structural Steel Frames

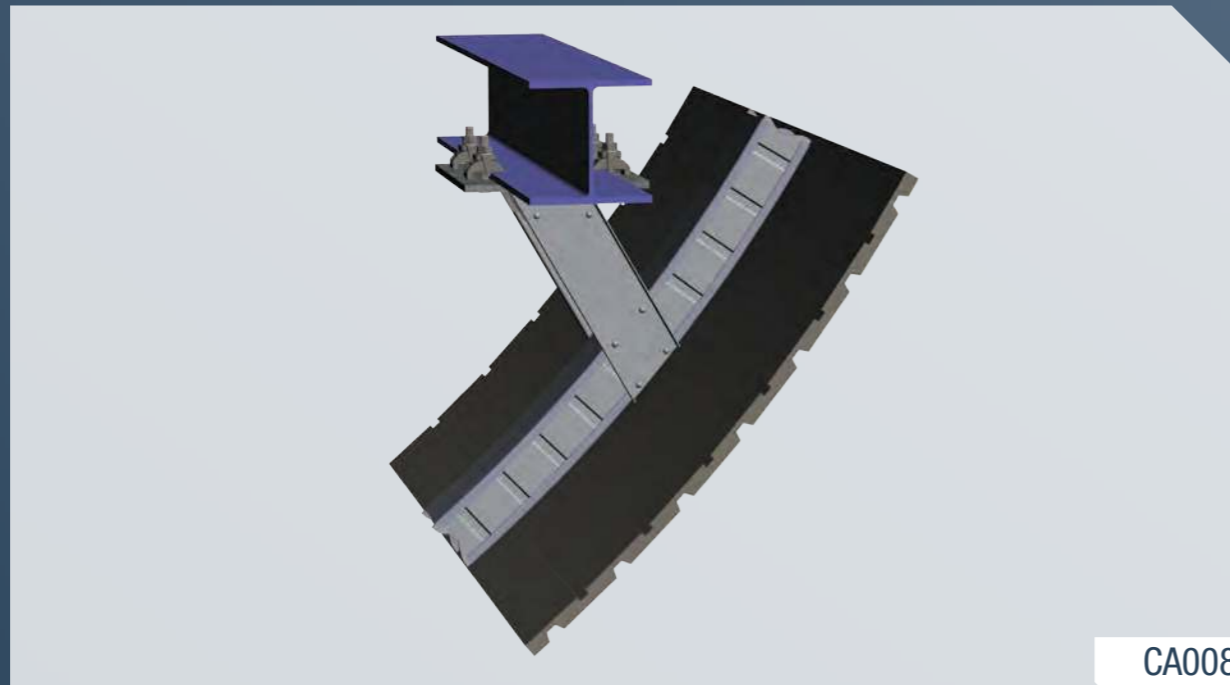

CA008

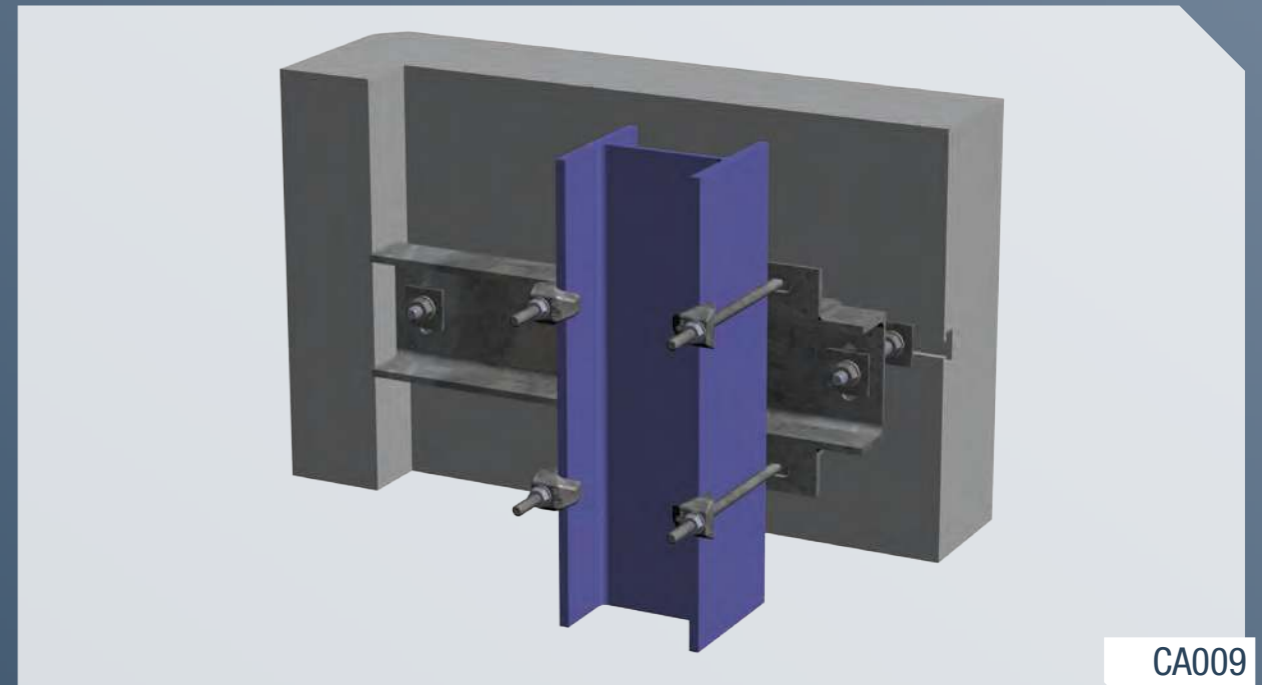

CA009

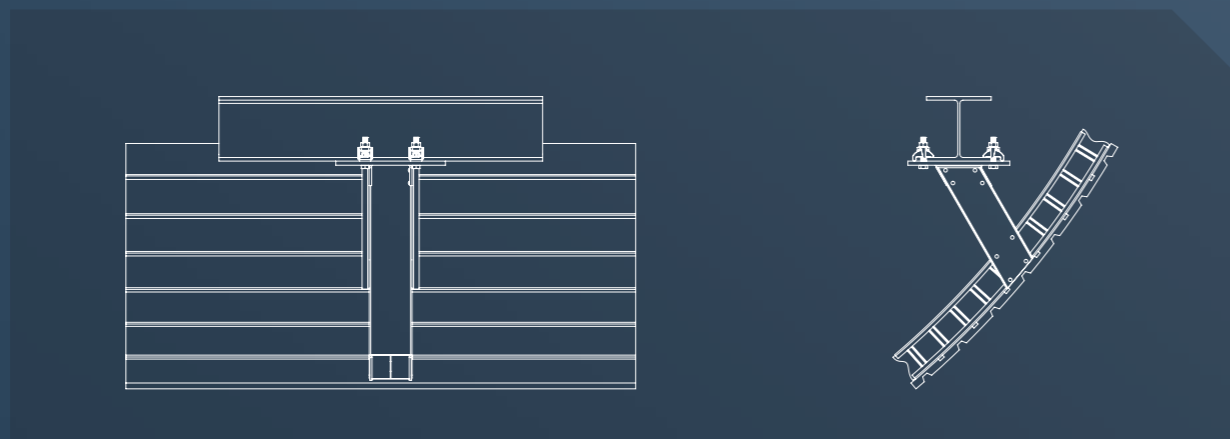

A roof canopy frame of a sports stadium is secured to primary structural steel with self-adjustable Type LR clamps. The fixings are compatible with a range of flange thicknesses and the use of slotted location plates allows easy alignment of the soffit panels.

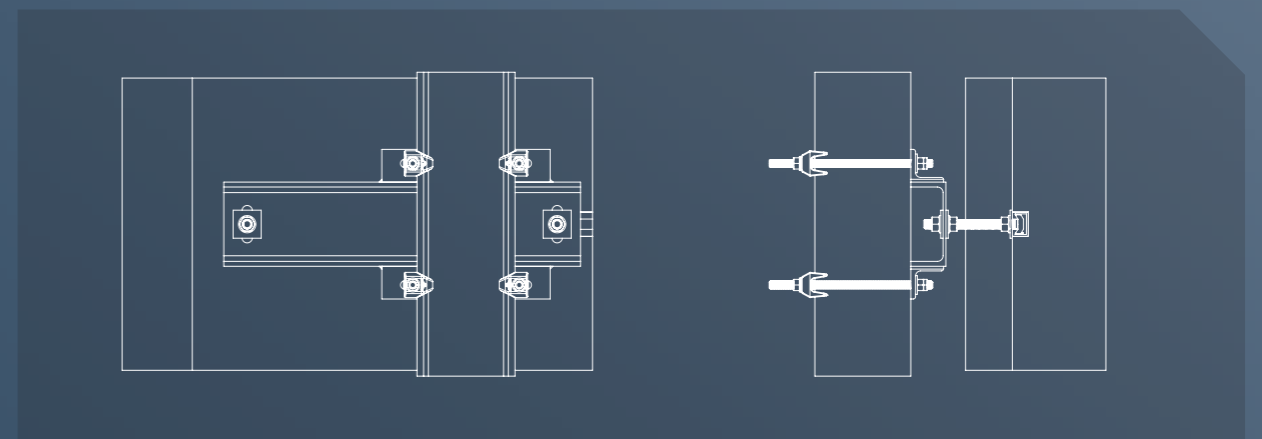

Sandstone faced precast concrete panels are connected to the structural steel of a new retail park development. The fixing assembly uses Lindapter Type CF high friction clamps, permitting simple vertical adjustment during the installation process.

Structural Hollow Section



Square/rectangle Structural Hollow Section (SHS) is a popular material amongst architects, with many contemporary designs featuring the exposed smooth profiles of the structural steel to enhance the aesthetics of a building.

Responding to industry demand for a faster alternative to welding or through-bolting, Lindapter invented the Holo-Bolt®, a structural expansion bolt specifically designed for primary or secondary connections of SHS. The Holo-Bolt is particularly well suited to external or internal glazing support frames due to its discreet profile. Installation is carried out quickly and safely by inserting the product into pre-drilled holes then tightening to the recommended torque using only hand tools.

CE The entire Holo-Bolt range has been awarded CE certification, independently verifying product performance in safety critical applications. Hexagonal, Flush Fit, Countersunk and Button/Security head variants in lengths 1, 2 and 3 are covered by ETA-10/0416. For more information visit: www.lindapter.com/about/ce

This section of the brochure provides examples of cost efficient methods of connecting façade panels and curtain walls to SHS. The Holo-Bolt can be used in a wide range of primary or secondary connections, including specialist applications such as blast resistance cladding. Please contact Lindapter's Technical Support Department to discuss your specific connection requirement.

Recommended products:

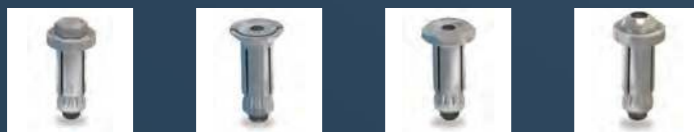

Holo-Bolt
(Hexagon Head)

Holo-Bolt
(Flush Fit)

Holo-Bolt
(Countersunk Head)

Holo-Bolt
(Button Head)

Please refer to the Lindapter catalogue or website for full product data

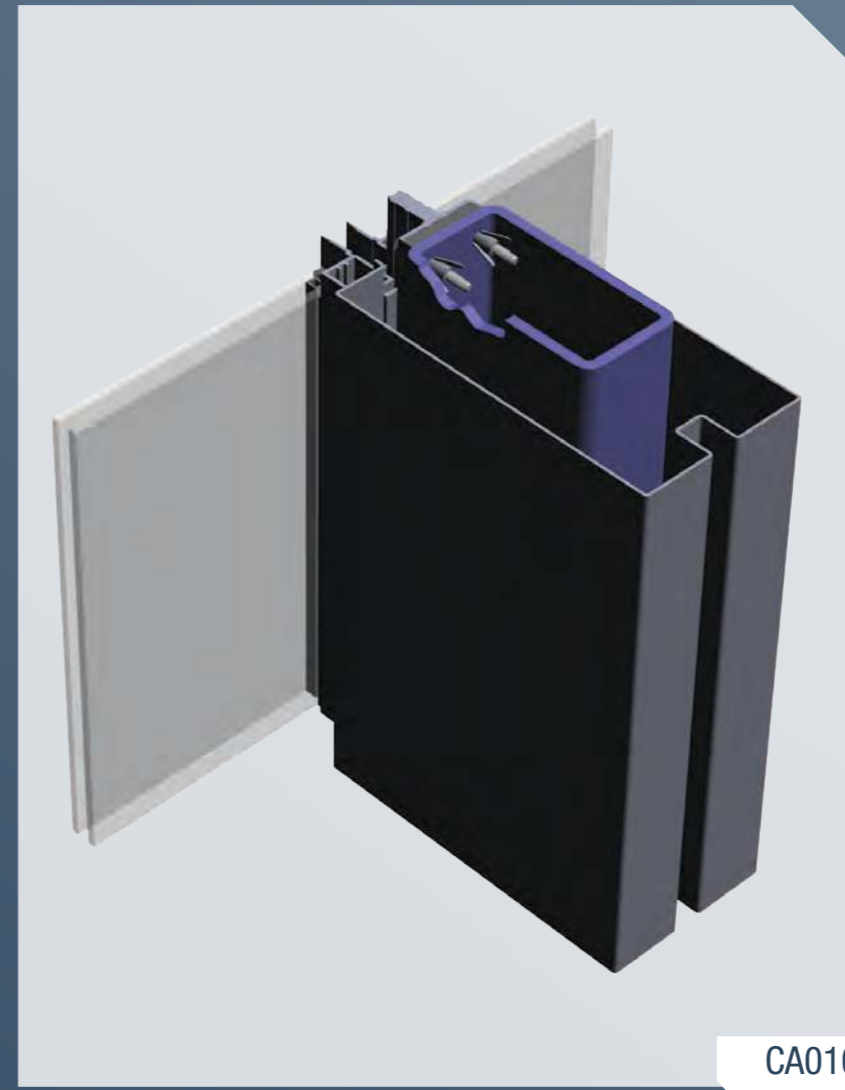

CA010

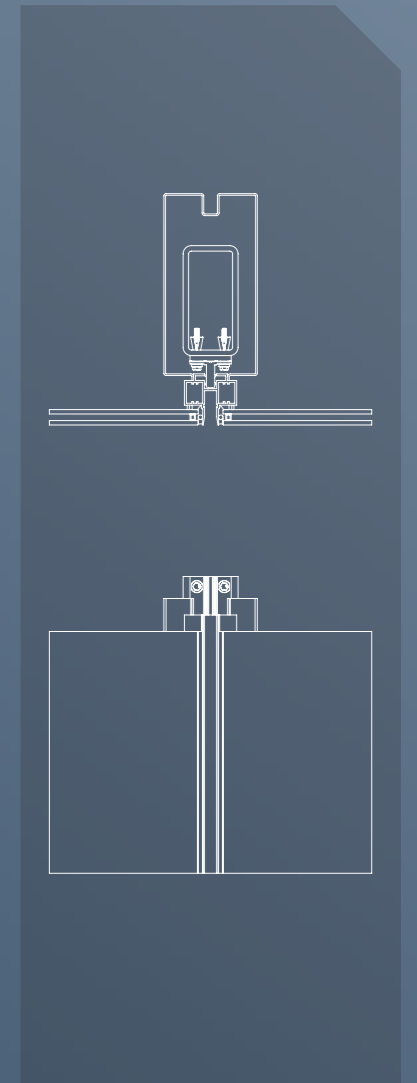

The Holo-Bolt, Lindapter's flagship expansion bolt, is designed to connect to SHS. In this application, a glazing system is attached to vertical SHS columns.

Structural Hollow Section

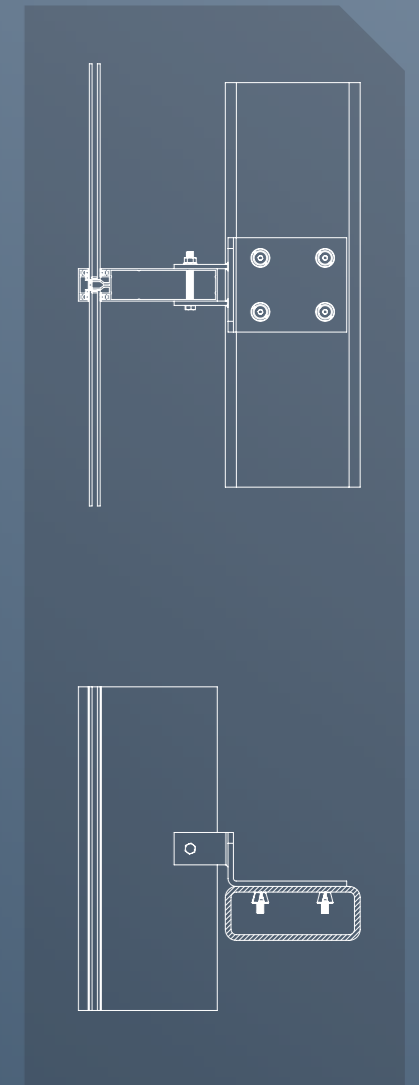
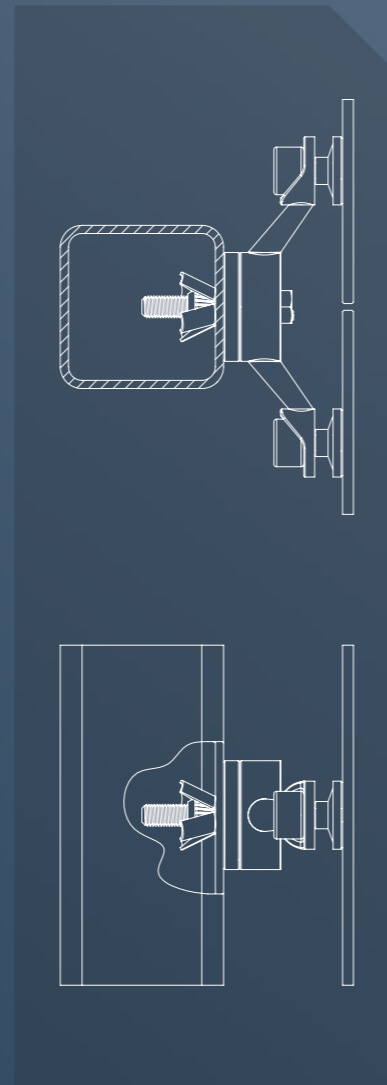
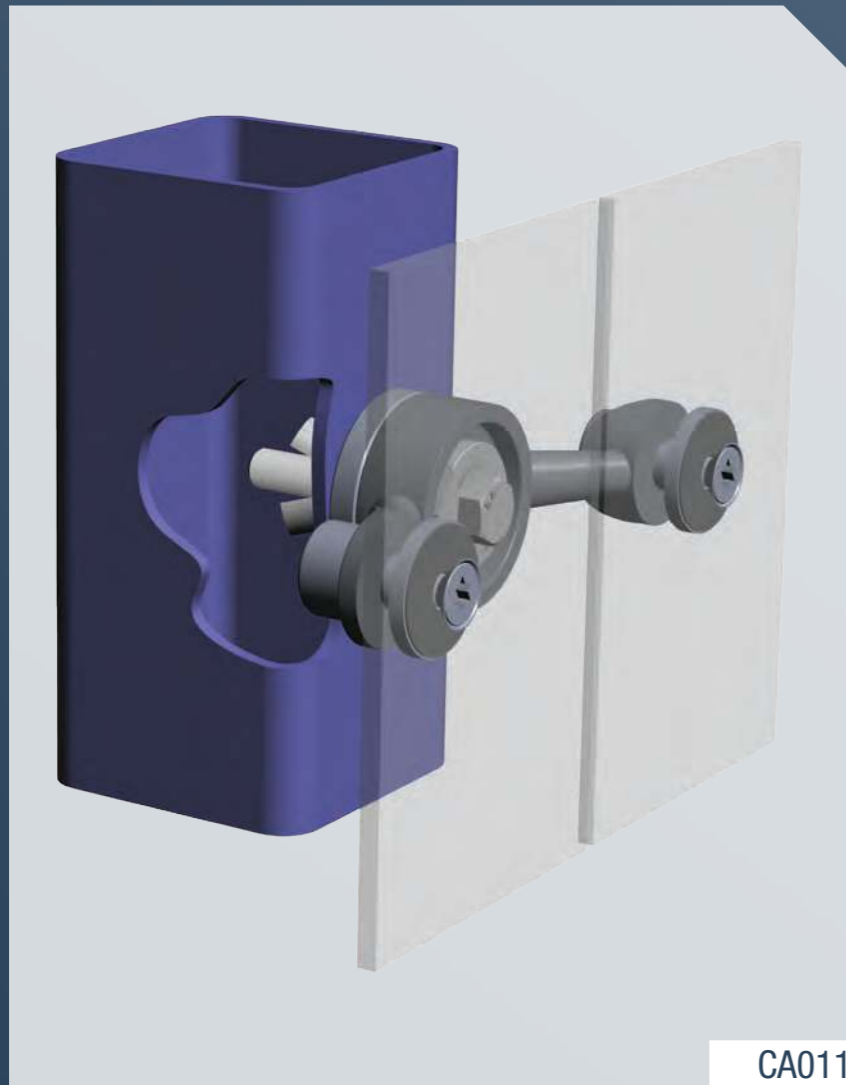

A two arm spider bracket is connected to SHS, allowing a frameless glazed atrium to be presented with style.

A curtain wall system is secured to horizontal SHS with the Holo-Bolt Flush Fit. The discreet expansion bolt is concealed within the bracket and supporting steel for an aesthetically pleasing finish.

Structural Hollow Section

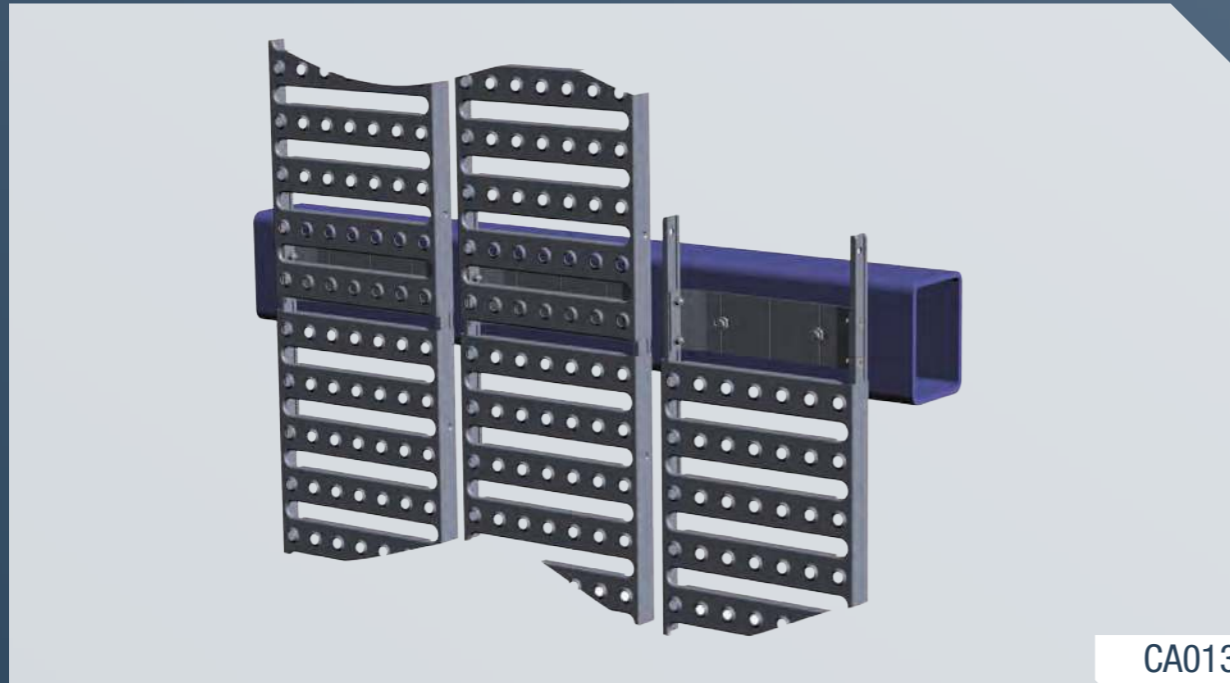

CA013

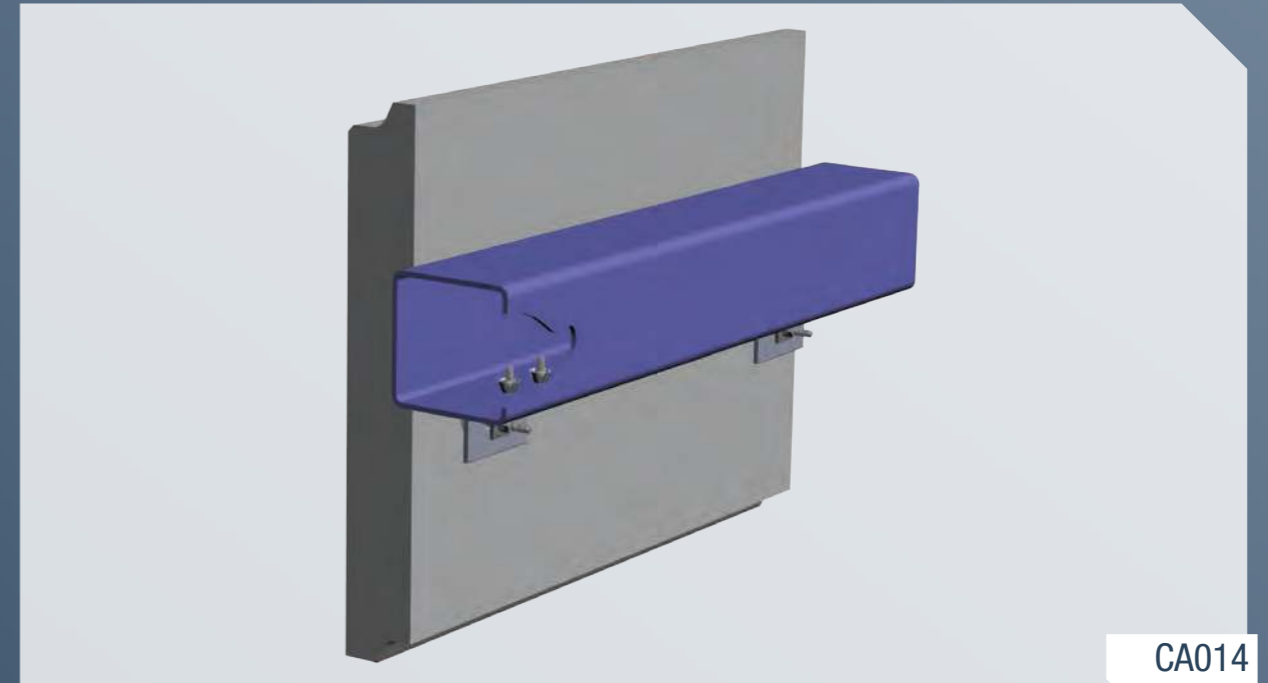

CA014

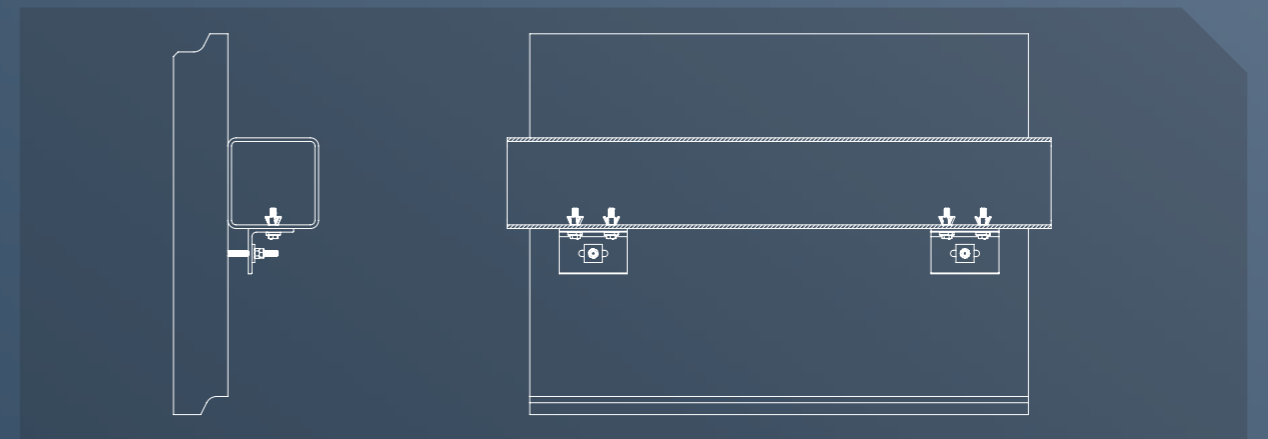
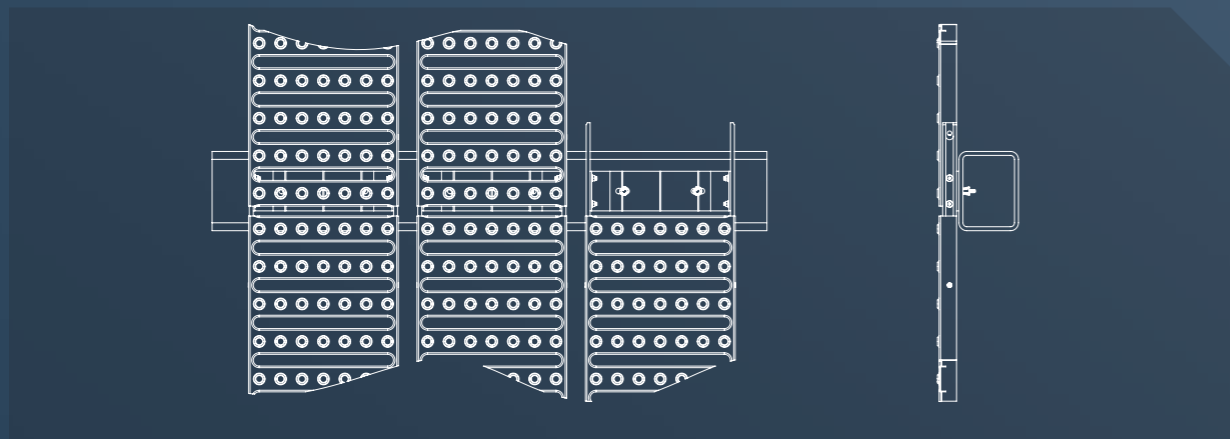

Lindapter's Holo-Bolt connects perforated steel cladding to horizontal SHS. This arrangement allows simple vertical and lateral adjustment for precise alignment of the panels.

Insulated wall panels attached to SHS using a simple angle bracket and Lindapter Holo-Bolts.

Steelwork



Behind a structure's façade, there is often secondary steel framework, Lindapter Girder Clamps provide a faster alternative to traditional connection methods, compatible with almost any shape and size of section, in a wide variety of applications.

The Girder Clamp symbolises Lindapter's philosophy perfectly; boldly challenging the need to drill or weld, when a safe, high strength connection can be quickly accomplished by clamping two steel sections together. Although the concept is simple, Lindapter products undergo complex design and testing as the experienced Research & Development team constantly refine, improve and invent to achieve greater product performance, verified by independent product approvals.

The following pages show typical applications. Please refer to the Lindapter catalogue / website for further examples, or contact Lindapter's Technical Support department to discuss your connection requirement.

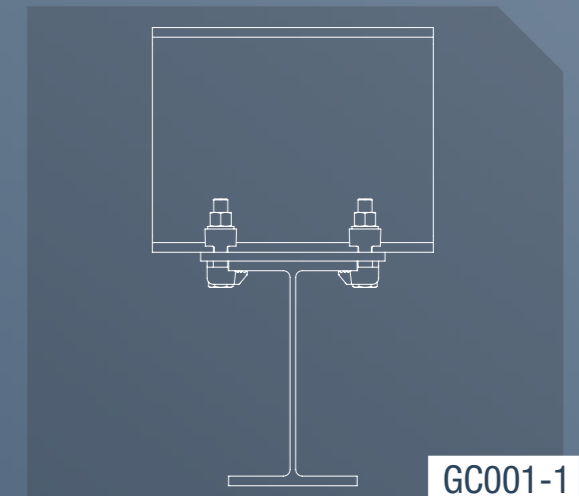

GC001-1

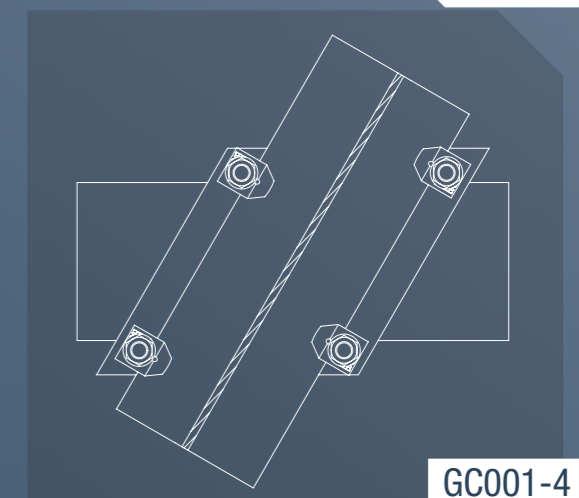
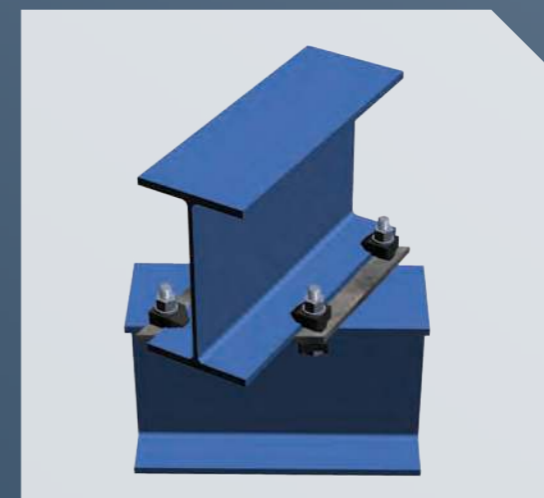

GC001-4

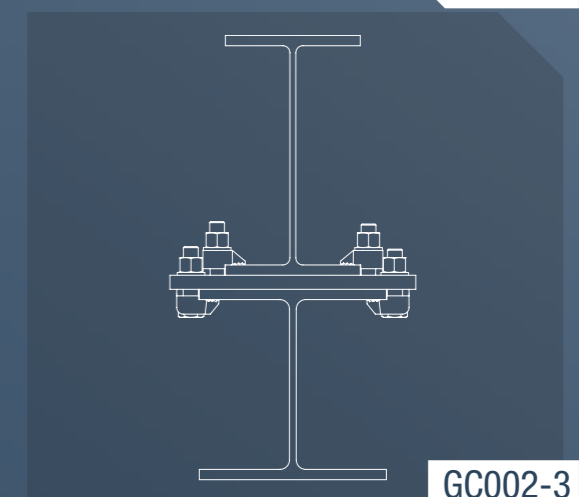
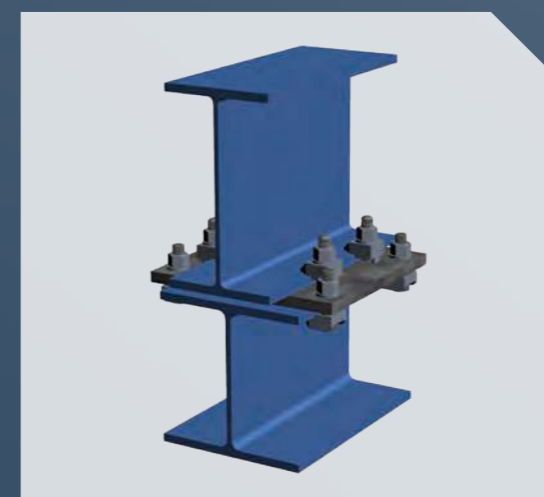

GC002-3

Recommended products:



Girder Clamp Type A Type B Type LR Type AF Type CF Type LS

Please refer to the Lindapter catalogue or website for full product data

Steelwork

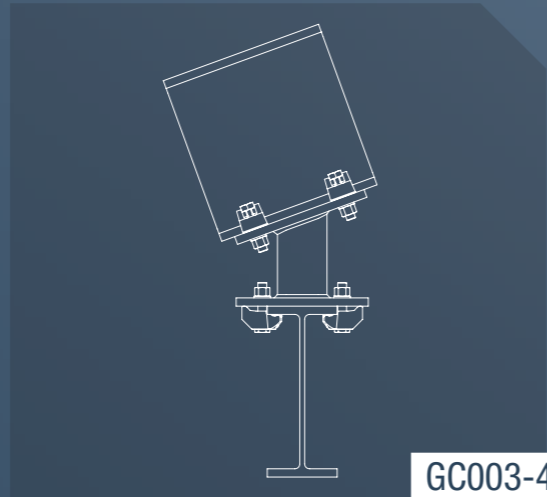
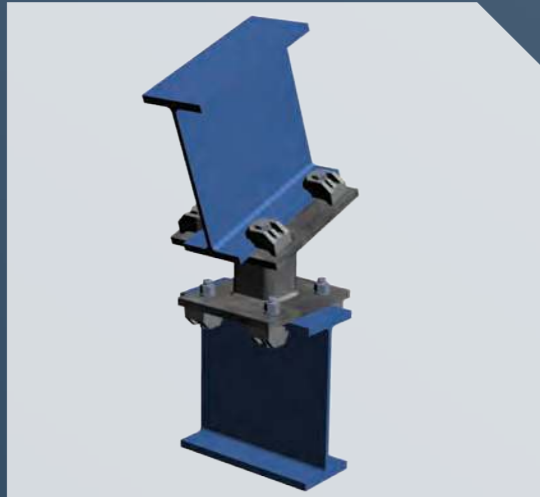

GC003-4

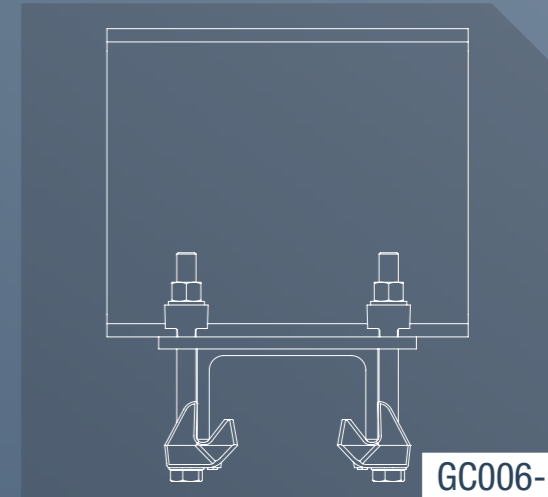

GC006-1

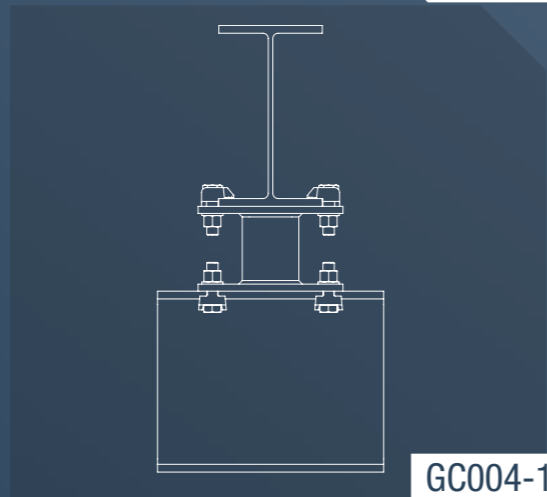

GC004-1

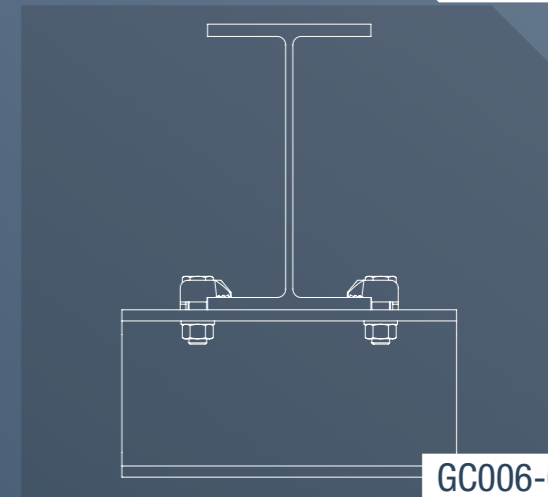
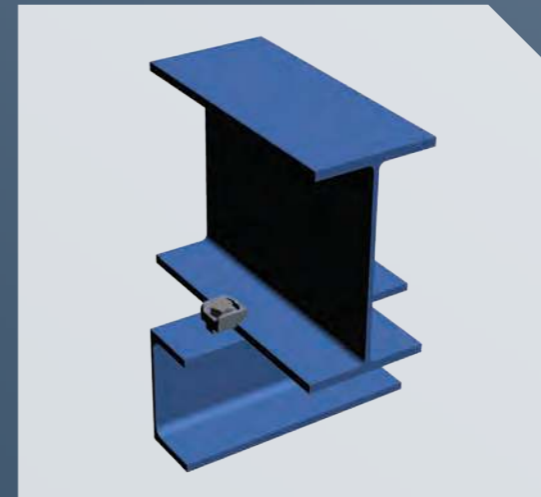

GC006-6

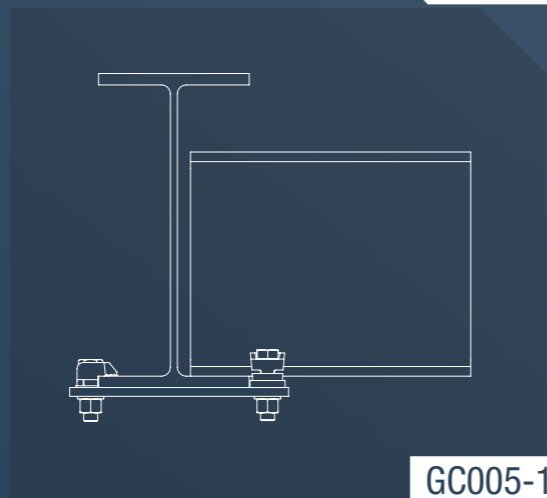
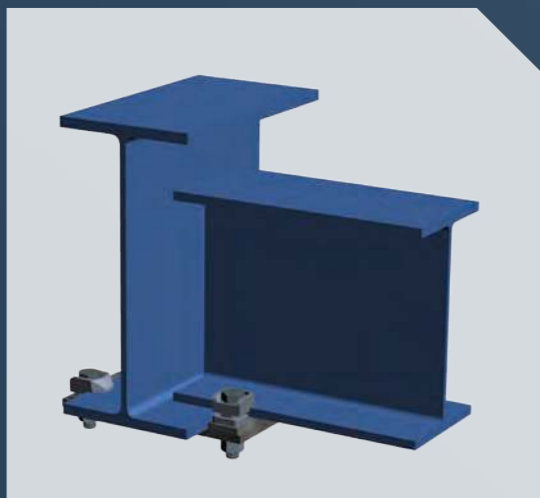

GC005-1

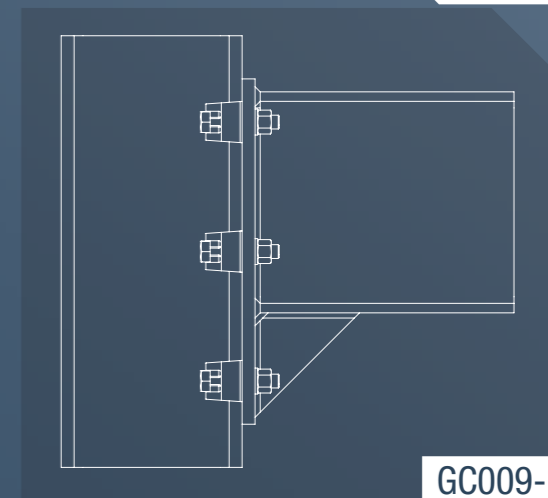
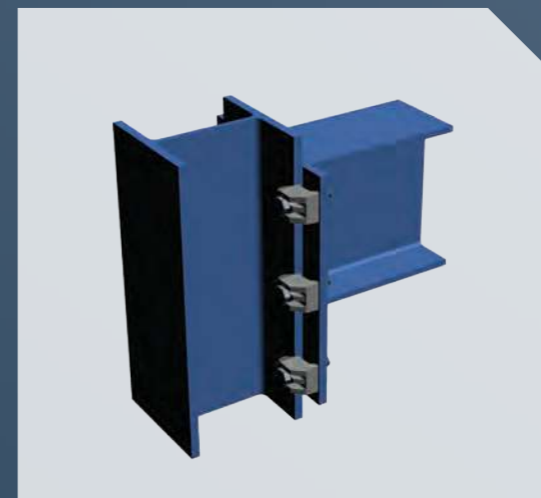

GC009-1

Experience

Location	Project	Application	Product
Australia	Eureka Tower, Melbourne	Exterior Sculptures	HB
Canada	The Bow, Calgary	Façade	HB
France	Société Générale Salle des Marchés, Paris	Glazing	HB
Germany	Esprit Arena, Düsseldorf	Roof	HB
Germany	Evonik Park, Heme	Façade	AF
Germany	Federal of Ministry Transport, Berlin	Glass Façade	A & B
Germany	Furniture Store, Uelzen	Glass Façade	HB
Germany	Garmisch Partenkirchen Ski Jump, Bavaria	Façade	A & B
Germany	Gas Station, Münster	Roof Façade	HB
Germany	HafenCity, Hamburg	Glazing	HBFF
Germany	Military Historical Museum, Dresden	Glass Façade	HB
Germany	Police Helipad, Frankfurt	Façade	HW / HC
Germany	Porsche, Leipzig	Façade	HB
Germany	Seminar Centre, Duisburg	Glass Façade	A & B
Germany	Shopping Centre, Heilbronn	Façade	A & B
Germany	Sparkasse Heilbronn	Exterior Sculptures	HB
Germany	Train Station, Dresden	Roof Façade	HB
Germany	Train Station, Wiesbaden	Roof Façade	HB
Holland	Train Station, Leiden	Roof	A
Ireland	Dublin Airport Terminal 2, Dublin	Aluminium Curtain Walling	HB
Ireland	Rugby Stadium, Dublin	Roof Façade	HB
Italy	Armani Hotel, Milan	Cladding	A
Italy	Progetto Portello, Comparto U3, Milan	Façade	A
Luxembourg	Swimming Pool, Luxembourg	Façade	HB
Qatar	NDIA Aircraft Maintenance Hangar, Doha	Aluminium Curtain Walling	HB
Singapore	Marq Project, Singapore	Curtain Walling	HB
Switzerland	Learning Center, Lausanne	Glass Façade	A & B
UAE	Financial Centre, Abu Dhabi	Glass floor	LS
UAE	World Trade Centre, Dubai	Roof	A
UK	Cabot Circus, Bristol	Glazing	HB
UK	Crown Square Courts, Manchester	Glazing	HB
UK	Inland Revenue, Cumbernauld	Cladding	LB2
UK	Piccadilly Station, Manchester	Roof	A & B
UK	Sainsbury's, Newcastle under Lyme	Glazing	HB
UK	St David's Shopping Centre, Cardiff	Façade	LR
UK	St Pancras Station, London	Glazing	A & B
USA	Minnesota Twins Ball Park, Minneapolis	Canopy Soffit	LR

St David's Shopping Centre Cladding

Location: Cardiff

Lindapter Type LR clamps were used to attach the precast concrete cladding panels to primary steelwork as part of the £675m expansion of St David's Shopping Centre in Cardiff.

The consulting engineers invited Lindapter to design a bespoke adjustable fixing system to facilitate the accurate positioning of precast concrete cladding panels on this major retail construction project. Lindapter proposed a solution comprising of a steel bracket with slotted holes that could be clamped to the structural members with Type LR fixings. The cladding panels could then be lifted into place and connected back to the same steel bracket, with the fixing system providing convenient adjustability on three axes.

The design was promptly approved and Lindapter supplied 534 pre-assembled connection systems, fitted with size M16 Type LR clamps, to secure the entire sandstone faced façade. The highly adjustable system not only simplified the positioning of the panels, but the self-adjusting capability of the Lindapter Type

LR allowed this specification to be standardised to accommodate dimensional variations of the structural steel.

Stephen Maddalena, Chairman and Joint M.D. of the Marble Mosaic Company, who designed, manufactured and installed the precast cladding panels, highlights the benefits of specifying Lindapter:

"Given the project's construction and programme constraints, the use of Lindapter's connectors provided an eminently practical means of attaching the precast cladding panels to its structural steel frame and the helpful support of Lindapter's team proved to be especially valuable in developing this solution"

St David's opened on schedule to become home to 88 new stores. The clean and contemporary appearance of this landmark British Shopping Centre has made a bold contribution to the rejuvenation of the Welsh capital.



Quality

Accredited to ISO 9001 since 1986, Lindapter strictly enforces a quality management system that includes vigorous product testing to ensure consistently high manufacturing standards.



Q 05143

Environment

Lindapter operates an ISO 14001 certified environmental management system and constantly monitors and improves aspects of the business that may have an impact on the environment, including the use of natural resources, the handling and treatment of waste, and energy consumption.



EMS 546660

Approvals

Lindapter has manufactured to the highest standard for over three quarters of a century, earning a multitude of independent approvals and a reputation synonymous with safety and reliability. Current accreditations include:

CE Marking

For Lindapter products in compliance with the provisions of the EC Construction Product Directive 89/106/EEC, please refer to the website: www.lindapter.com/about/ce



Deutsches Institut für Bautechnik
Deutsches Institut für Bautechnik approves construction products for use in structural and civil engineering industries in Germany.



Lloyd's Register Type Approved
Lloyd's Register Type Approved products have been subjected to tensile, frictional, shear, vibration and shock tests, witnessed and verified by Lloyd's Register.



TÜV
TÜV is the certifying authority for safety, quality and environmental protection in Germany.



Det Norske Veritas
Det Norske Veritas has approved the use of Lindapter products in lifting applications. This includes their use on both mobile and fixed offshore installations.



Factory Mutual
Factory Mutual, the American insurance organisation, offers an approval that is recognised by the fire protection industry world-wide.



Verband der Schadenversicherer e.V.
Verband der Schadenversicherer e.V. is one of Germany's leading independent testing institutions for products used in fire protection applications.



Lindapter is a member of the following organisations:



Technical Support

Experienced engineers offer an unrivalled support service, including free design and bespoke new product development. Lindapter's philosophy is to deliver the highest quality at every stage of the service, from initial connection design to installation guidance.

- Specialist advice from experienced engineers
- Free connection design based upon your requirements
- Bespoke drawings delivered in 2D and interactive 3D formats
- CAD files available to import into all major software applications
- Contractor training and onsite visits (where required)

Engineered Solutions

- Design and development of custom products
- Manufactured to Lindapter's exacting standards
- Thoroughly tested with detailed reports



Distributeur agréé pour la France
MAURIN FIXATION

Siège social

LYON
13, rue du Souvenir
BP 9271 - 69264 LYON Cedex 09 - France
Tél. : 33 (0)4 72 85 85 85
Fax : 33 (0)4 78 83 21 78
fixations@emile-maurin.fr

The Lindapter logo is rendered in a bold, white, sans-serif font. The letter 'l' is lowercase and features a distinctive hook that extends to the left. The remaining letters 'indapter' are in a standard uppercase weight.

Distributeur agréé pour la France

 MAURIN FIXATION

The Maurin Fixation logo consists of a blue square icon containing a white stylized arrow pointing towards the top-right corner. To the right of this icon, the words 'MAURIN FIXATION' are written in a bold, black, uppercase sans-serif font.

Siège social

LYON

13, rue du Souvenir

BP 9271 - 69264 LYON Cedex 09 - France

Tél. : 33 (0)4 72 85 85 85

Fax : 33 (0)4 78 83 21 78

fixations@emile-maurin.fr