

Data Centres

lindapter[®]

Technical Innovation in
Steelwork Connections

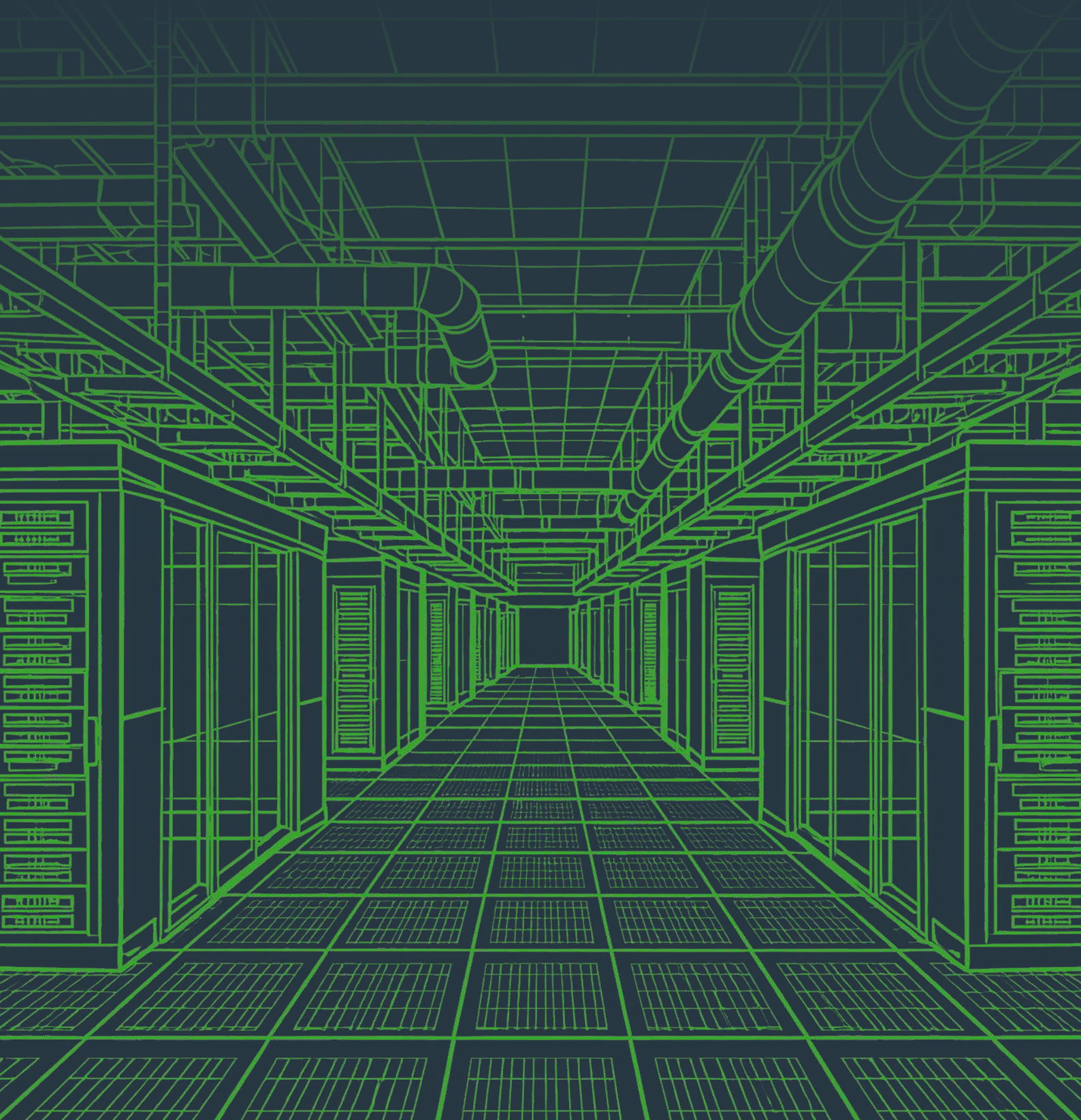

Lindapter®

Technical innovation in steelwork connections since 1934

Lindapter provides a unique range of approved steelwork solutions for overcoming challenging steel-to-steel connections. Our products are used extensively around the world and are the ideal solution for Data Centre projects, with no site welding or drilling required.

Whether securing ceiling grids, multi-tier pipe supports, containment aisle modules, MEP services, steelwork or steel flooring in new build or refurbishment projects Lindapter has a proven, accredited and safe connection solution.

If you are a data centre client, contractor or specifier then your projects and installations could benefit from Lindapter innovative steelwork clamping systems that provide a faster, safer and more cost-effective alternative to drilling or welding.

CONTENTS

3 Product Range Overview

OUR SOLUTIONS

4 - 5 Hollo-Bolts

6 - 10 Girder Clamps

11 Decking Fixings

12 Support Fixings

13 Floor Fixings

14 Technical Support & Service

15 Accreditations & Approvals

KEY BENEFITS



No Welding

Say goodbye to the hazards and time-consuming process of welding. Lindapter allows for cold connections, eliminating the need for hot works, which increases safety and reduces onsite risk.



No Drilling or Bolting

Traditional methods of securing steel require intensive labour and time. With Lindapter, you can bypass the need for drilling or bolting, preserving the integrity of structures and saving hours of labour.



Speed Of Installation

Maximise productivity with quick and easy installation methods. Our solutions are designed to minimise project timelines, saving you valuable time and labour costs.



Easy, Adjustable Installation

No need for heavy machinery or specialised equipment. Lindapter connections are installed using hand tools, allowing for easy adjustments and more flexible project management.



Fire Rated

Many Lindapters products are independently fire tested to provide additional compliance. The fire testing is carried out by UKAS accredited laboratories in accordance with BS EN 1991-1-2. The fire ratings of each product can be found on our website or emailing support@Lindapter.com



Approvals (see page 15)

For over 90 years Lindapter products have earned a respected reputation synonymous with safety and reliability due to its range of independent approvals. These approvals provide contractors with the evidence that the products are fit for purpose to help you prove compliance.

Product Range Overview



HOLLO-BOLT

Our expansion bolts require access to only one side of the Structural Hollow Section (SHS) and offer a faster alternative to welding or through-bolting, enabling contractors to reduce construction time and labour costs. Ideal applications include assembly of containment aisles and connecting modules together.

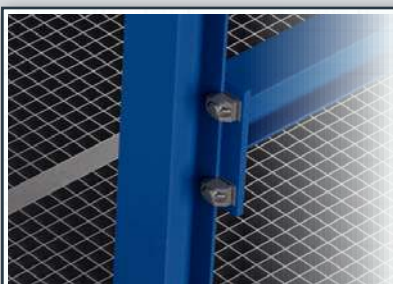

GIRDER CLAMPS

Steel sections are clamped together using girder clamp assemblies for a quick installation. This connection method is used extensively in data centre applications including ceiling grids, multi-tier pipe supports, MEP services supports, steel racks, strut channel supports plus many others.



DECKING FIXINGS

Building services are quickly attached to decking profiles using fire rated decking fixings without drilling the concrete deck. The fixings are installed inside the dovetail re-entrant channels of the decking profiles and provide a fixing point for suspending MEP equipment.



SUPPORT FIXINGS

Easy-to-install solutions for suspending building services from structural or secondary beams. The adjustability of these products allows the fast and precise alignment of items such as HVAC equipment, pipework, fire protection and sprinkler systems.

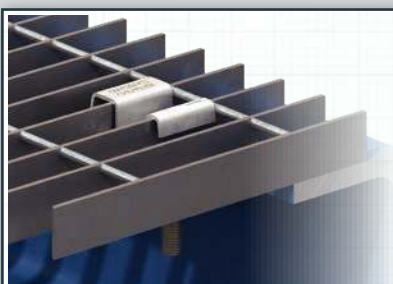

FLOOR FIXINGS

A range of innovative fixings for securing steel flooring to the supporting steelwork without the need for onsite drilling or welding. Access to the underside of the flooring is not required, eliminating the need for costly scaffolding or elevated floors.

Hollo-Bolt Solutions

TYPICAL APPLICATIONS



CONTAINMENT AISLE SHS FRAME SPLICE AND CORNER CONNECTIONS

Lindapter Holo-Bolts are used to connect the structural hollow sections of containment aisle frames.

A simple splice connection is made and because the Holo-Bolts only require access from one side less holes need to be drilled in the structural hollow sections.



SPLICE
CONNECTION



 **Hollo-Bolt™**

CORNER
CONNECTION

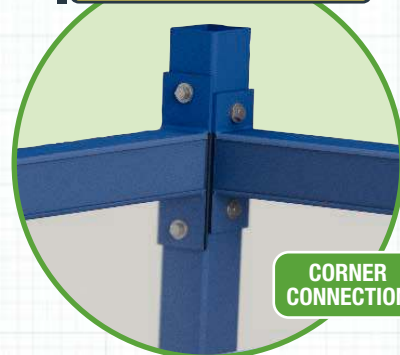

Hollo-Bolt Solutions

TYPICAL APPLICATIONS

CONTAINMENT AISLE CANTILEVER SUPPORT ARMS TO SHS FRAME CONNECTIONS

Lindapter Hollo-Bolts are used to directly connect cantilever support arms to the structural hollow sections of containment aisle frames. They are also used to connect strut vertically to the SHS which then allows adjustable strut support arms to be installed.

Once the support arms are installed equipment such as cable trays and piping can be laid across them and down the aisles.

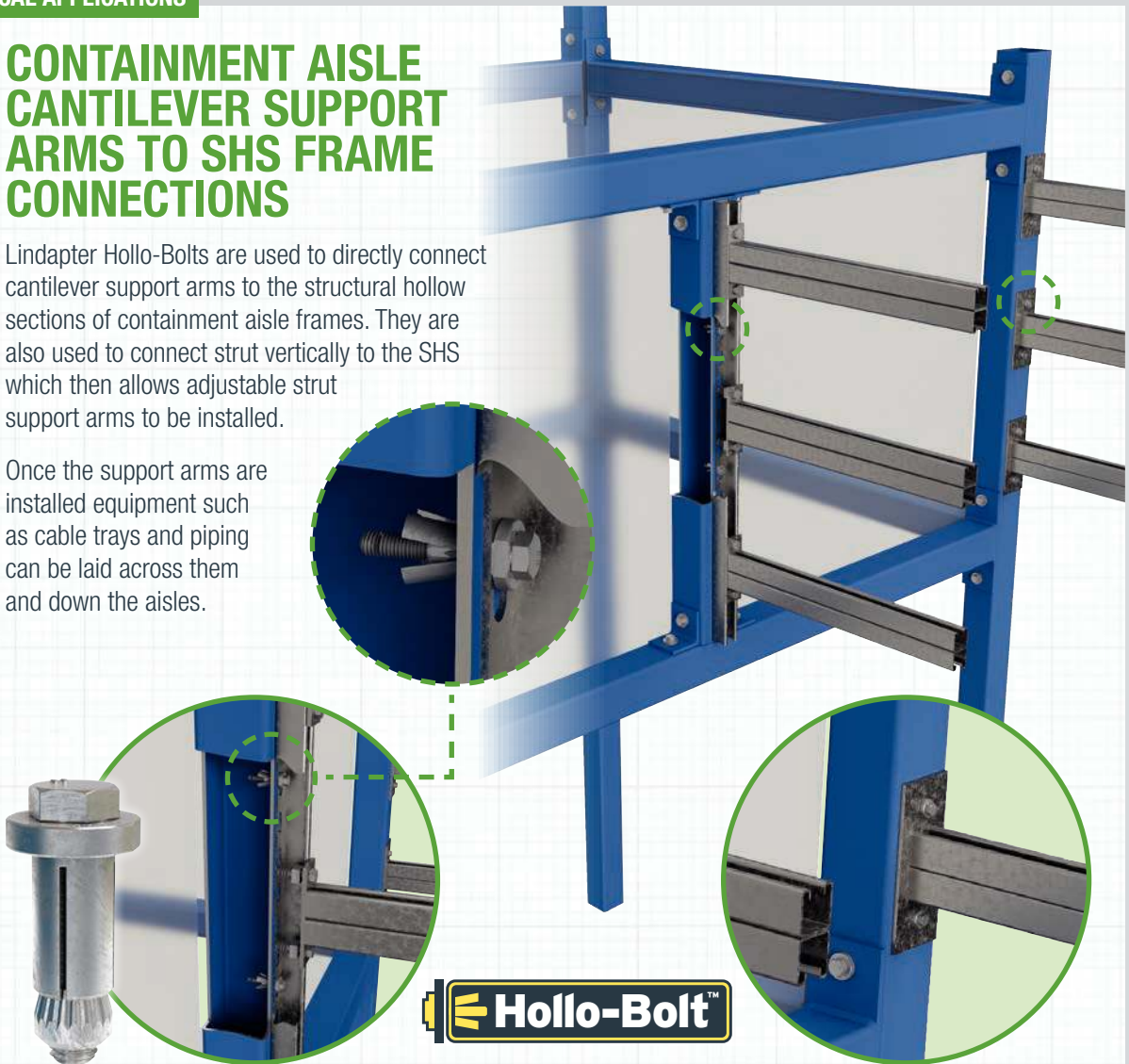

CONNECTING CONTAINMENT AISLE MODULES TOGETHER

Once onsite, Lindapter Hollo-Bolts are used to connect the containment aisle modules together.



Girder Clamp Solutions

TYPICAL APPLICATIONS

CEILING GRID TO PRIMARY STEEL

Heavy duty Type AF girder clamps are used to connect ceiling grids to the primary steel.

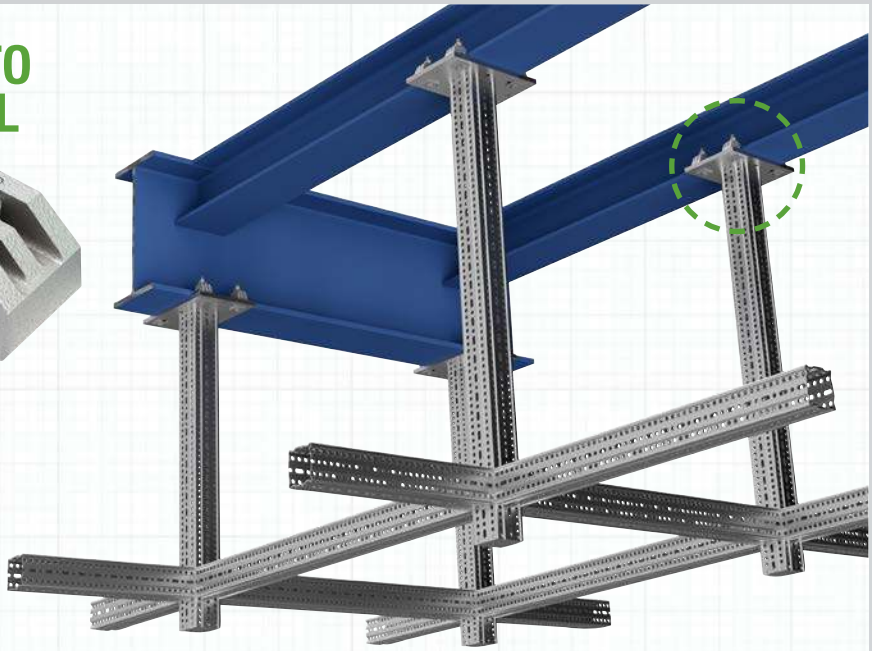

MULTI-TIER PIPE SUPPORTS

High slip resistance Type AF girder clamps and Type LR adjustable girder clamps are used to assemble pipe supports with high tensile and slip load capacities.

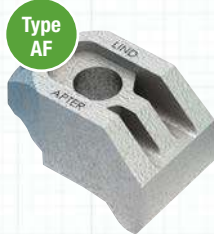

Girder Clamp Solutions

TYPICAL APPLICATIONS

HEAVY DUTY CHANNEL SYSTEM TO STEEL COLUMN

Type AAF high slip resistant girder clamps with location plates are used to connect heavy duty channel systems to the primary steel columns.

The channel system is then used to support multiple types of MEP services including pipework and electrical cable tray.



BACK-TO-BACK STRUT CHANNEL FRAMEWORK TO BEAM

Type AAF adjustable girder clamps with end plate creates a high strength connection between a back-to-back strut channel framework and primary steel beam. Containment aisle modules or MEP services can then be suspended from the strut channel framework.

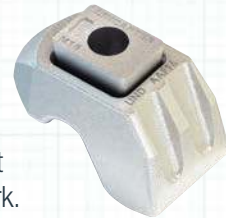

Girder Clamp Solutions

TYPICAL APPLICATIONS

STRUCTURAL STEEL RACKS

Type AAF and Type AF heavy duty girder clamps are used to connect the sections of structural steel racks or bays either offsite at the steel fabricators or onsite by contractors. Modular construction is becoming more popular as the demand for large scale data centres increases exponentially. Our girder clamps are quick and easy to install and remove the need to weld or drill the steel racks.

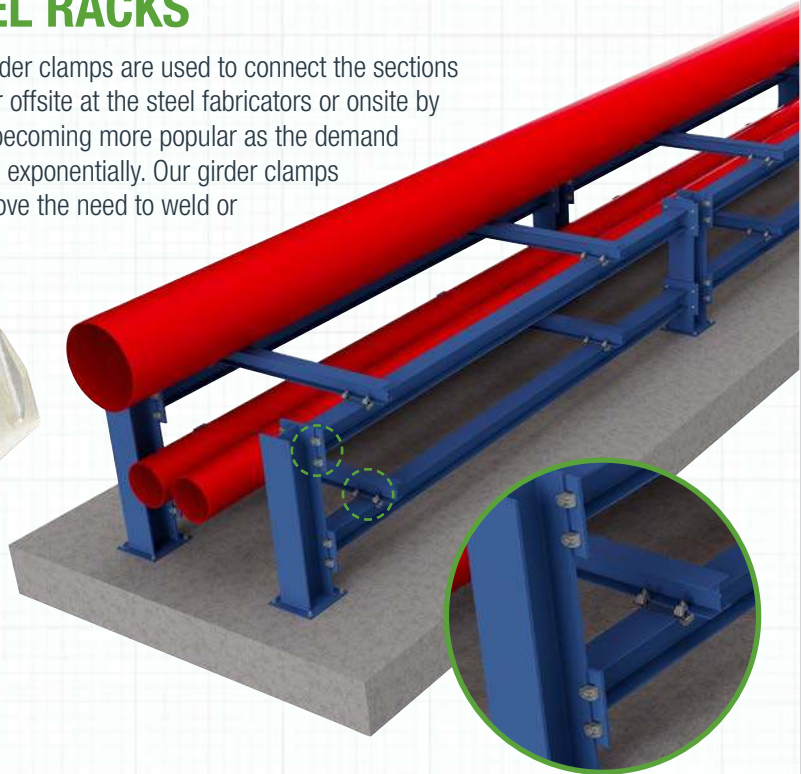

PIPE RISER SUPPORTS

Type CF high slip resistance girder clamps hook around the flange of horizontal beams and secure vertical pipework with threaded rod and insulated pipe clamps.

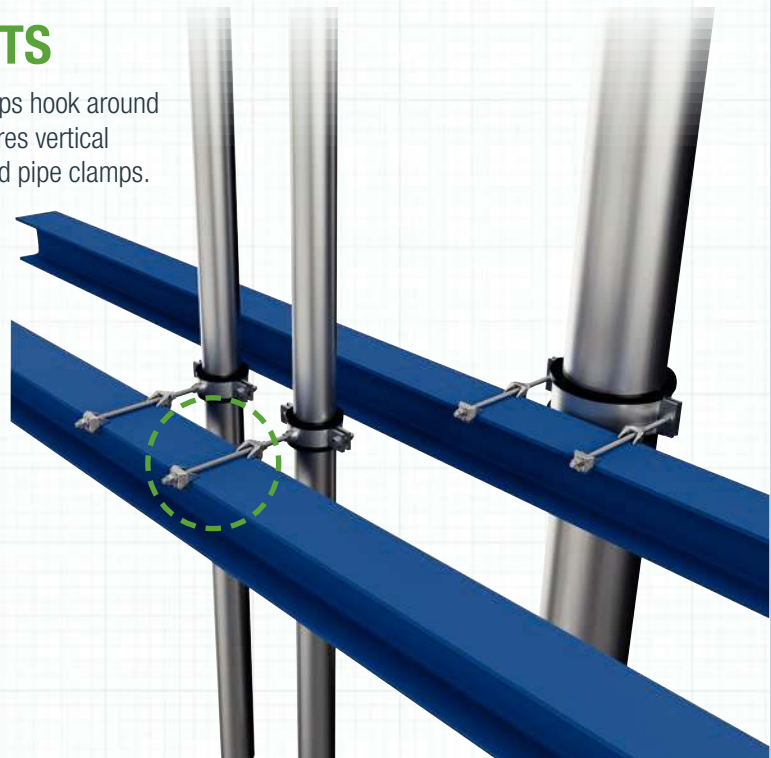
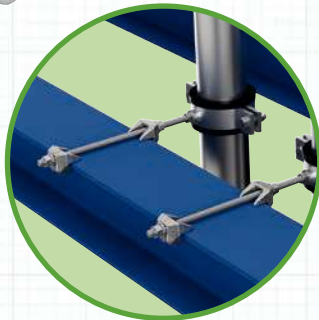

Girder Clamp Solutions

TYPICAL APPLICATIONS

STRUT CHANNEL SUPPORT TO COLUMN

Type CF high slip resistance girder clamps and brackets are used to connect strut channel to the flanges of the primary steel column.

The support can be used to hold cable tray or other MEP services vertically.

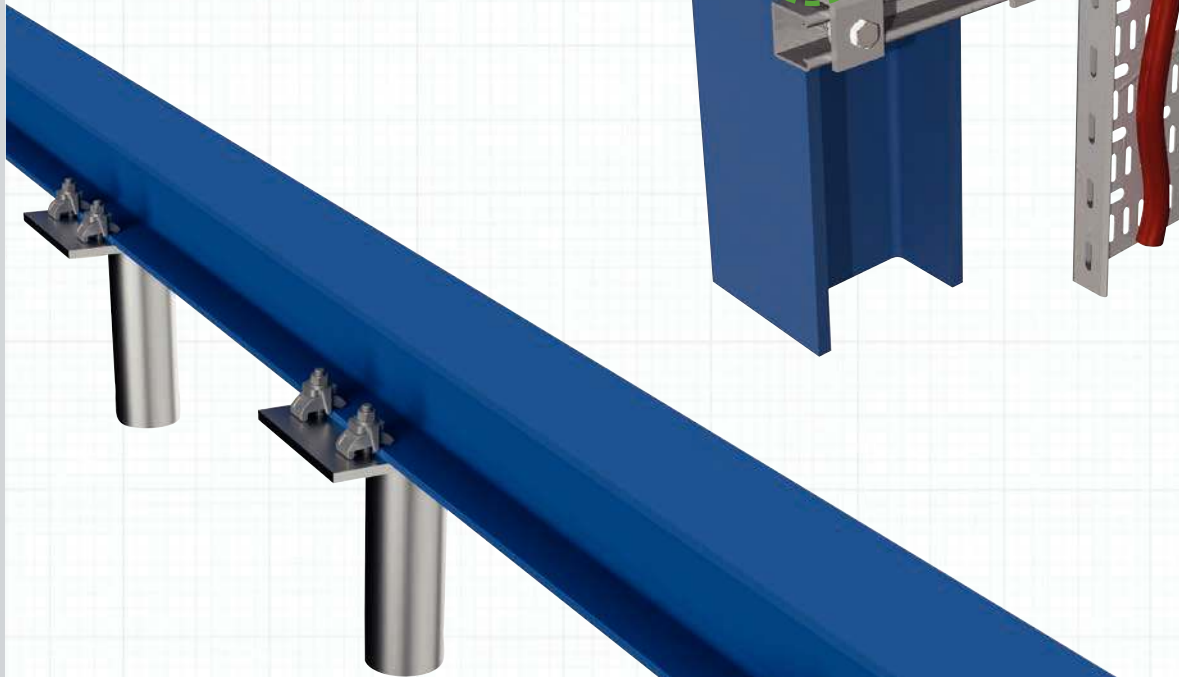
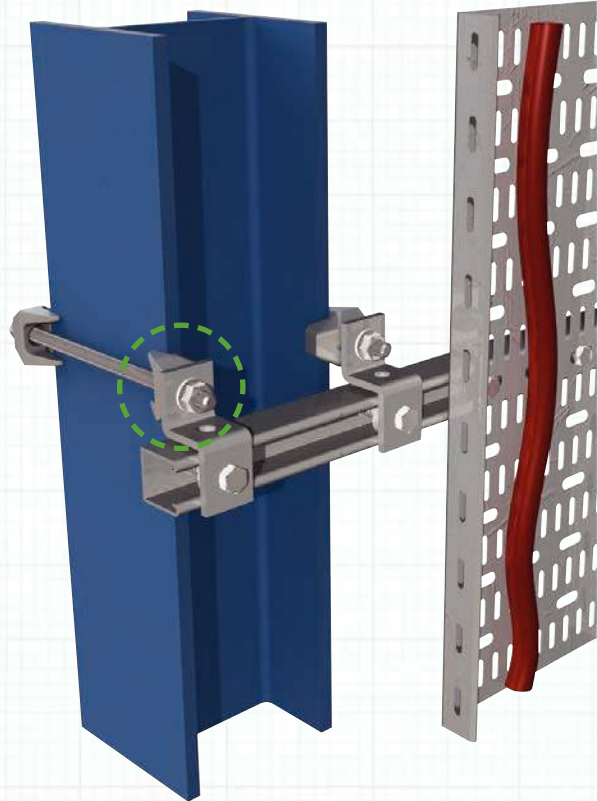

RAISED FLOOR TO STEEL FOOTINGS

Type LR adjustable girder clamps are used to connect raised floors to low level steel footings creating a concealed space beneath the floor, which is used for routing cables, power, and cooling air.

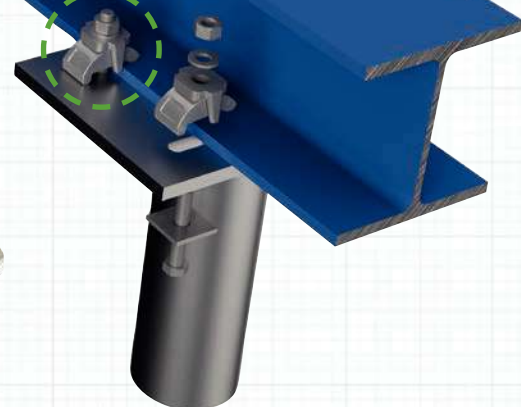

Girder Clamp Solutions

TYPICAL APPLICATIONS

CHILLER PLANT EQUIPMENT MOUNTING TO STEEL BASE FRAME

Type AAF high load capacity girder clamps with location plates are used to secure rooftop chiller units to the supporting steel base frame. This method provides a high strength connection, ensures accurate positioning, effective load transfer, and vibration resistance via the dampeners while eliminating the need for drilling or welding.

The clamping system also allows for adjustment during installation and facilitates future maintenance or equipment replacement without damage to the steel base frame.

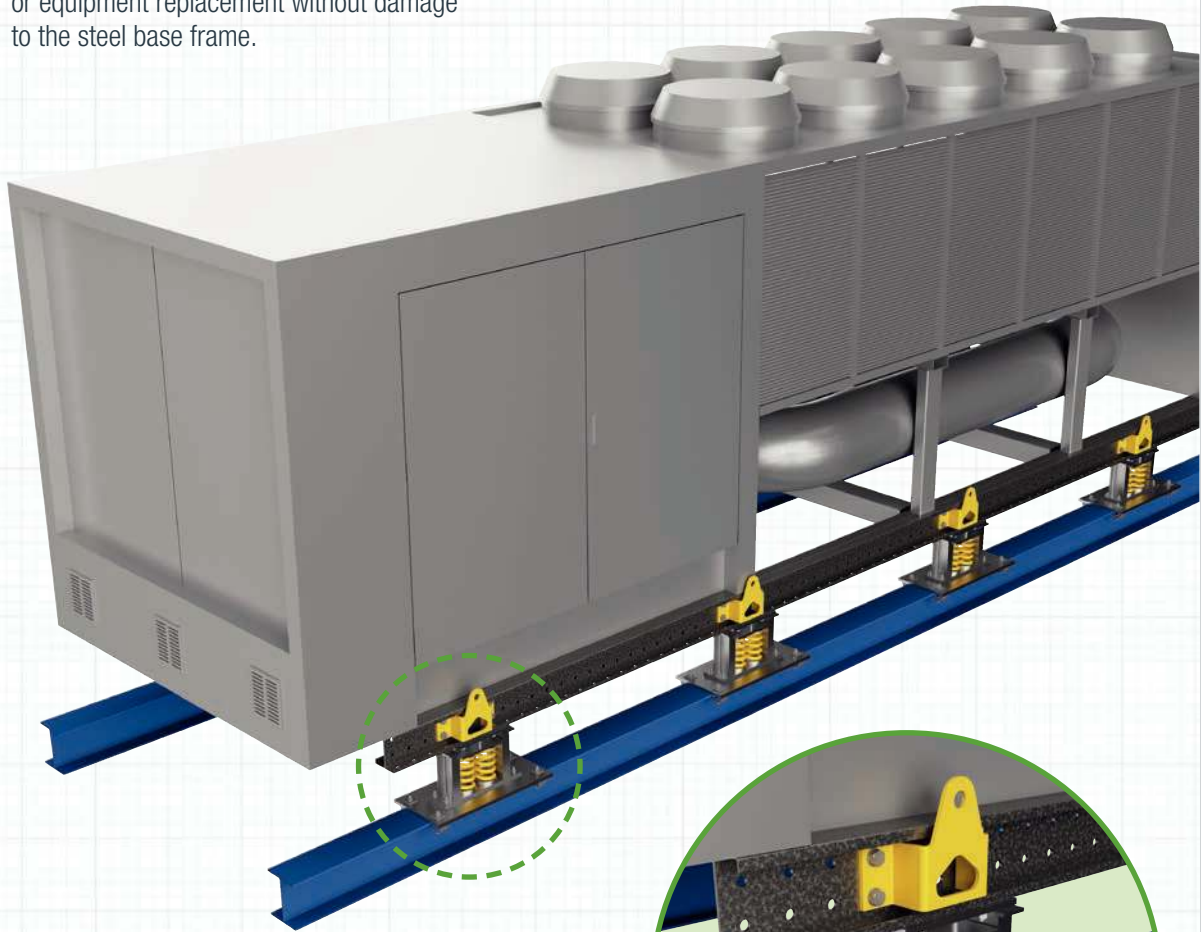

Decking Fixing Solutions

TYPICAL APPLICATIONS

STRUT CHANNEL TRAPEZE TO COMPOSITE DECKING PROFILE

Lindapter's zero-impact decking fixings in combination with threaded rod and strut channel are used to create a trapeze connected to the composite decking profile.

The trapeze can be used to hold cable tray, cable basket, pipes, HVAC systems or other MEP services.

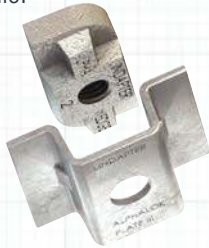

Pictured: Type MW2



STRUT CHANNEL HEADER TO COMPOSITE DECKING PROFILE

Lindapter's zero-impact decking fixings in combination with threaded rod are used to connect a strut channel header to the composite decking profile. Threaded rod is then attached to the strut in order to suspend large spiral ducting for HVAC systems or other MEP services.



Pictured: Type TR60



Support Fixing Solutions

TYPICAL APPLICATIONS

PARALLEL OR TAPERED FLANGE BEAMS & STRUT TRAPEZE

Type FL beam flange clamp with threaded rod and strut trapeze are used to suspend cable tray, cable basket, pipes, HVAC systems or other MEP services from primary or secondary steel beams.



BEAM FLANGE & DUCT SUSPENSION RING

Type F3 high strength beam flange clamp with threaded rod and duct suspension ring are used to suspend large spiral ducting for HVAC systems or other MEP services from primary or secondary steel beams.



Floor Fixing Solutions

PRODUCT RANGE

FLOORFAST®

Lindapter FloorFast can be used in data centre construction or refurbishment projects to quickly secure chequer plate flooring to supporting steelwork and can be carried out quickly and safely from above, often by one person, significantly reducing costs.

The stepped clamping face locks under the steelwork to provide a secure connection, data centre applications include walkways around plant rooms, UPS areas, battery rooms, and rooftop mechanical systems, raised floor areas, stairs and mezzanine floors.

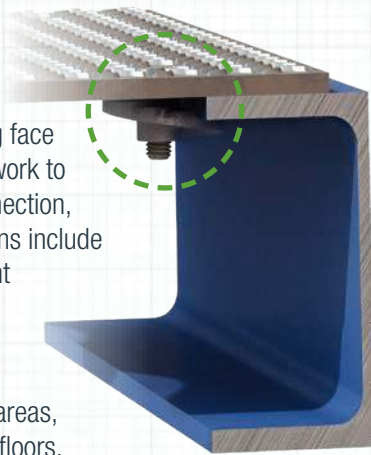
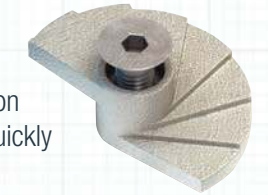

HOLLO-GRATE-FAST

NEW

Leveraging the high strength of the legendary Hollo-Bolt with the ease and convenience of the Grate-Fast, the **Hollo-Grate-Fast** quickly secures open bar grating to Structural Hollow Section (SHS).

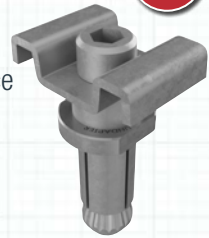

Developed specifically for the most common sized 19-W grating, our newest innovation allows grating to be connected to SHS without drilling, welding or powder actuated fastening on site.

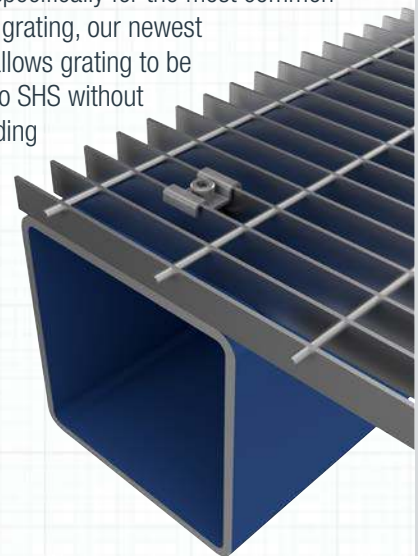

GRATE-FAST®

A high strength floor fixing for rectangular open bar grating, providing superior clamping force due to a malleable iron cast body. Lloyd's Register Type Approval for resistance to shock and vibration.



TYPE 1055

This unique solution enables solid steel plate flooring to be installed over the top of existing open-mesh or open-grid flooring using simple hand tools.

Retrofitting pedestrian walkways in this way is also a fire safety solution, in case of a fire the solid steel plate flooring acts as a barrier to flames.

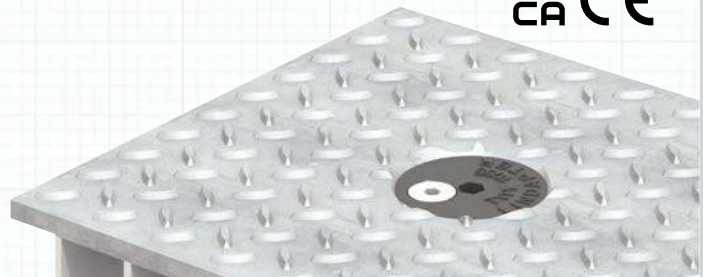
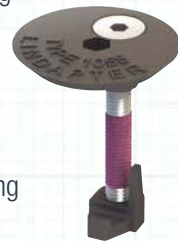

Technical Support & Service

WE ARE HERE TO HELP

Lindapter offers an extensive range of technical support and services to help you achieve the optimum solution for your next project or application. Our philosophy is to deliver the highest level of service from initial design through to installation guidance.

ONLINE GIRDER CLAMP CONFIGURATOR

Lindapter's new online design tool for engineers and specifiers produces fully detailed connection drawings within seconds. Find your next solution at www.Lindapter.com

FREE CONNECTION DETAILING

Lindapter can design a bespoke connection based on your specific requirements free of charge.

Our Technical Support Engineers will supply customised CAD drawings and BIM compatible files to complement your designs.

CHARACTERISTIC RESISTANCES

When designing a connection to Eurocode 3 please refer to our Declaration of Performance certificates that are available to download from www.Lindapter.com. For applications with unusual loadings or where dynamic conditions are present contact Lindapter technical support.



Accreditation & Approvals

INDEPENDENT PRODUCT APPROVALS



CE Mark

Provides additional assurance that a product complies with the EU Construction Product Regulation and will perform as stated in the corresponding Declaration of Performance (DoP). DoPs list Characteristic Resistances for use when designing connections to Eurocode 3.



UKCA

Demonstrates compliance with the Construction Products Regulation in Great Britain. Independently verified product specification data, including Characteristic Resistances for designing connections to Eurocode 3 are published in Declaration of Conformity (DoC) documents.



Fire Ratings

As part of our continued commitment and investment in product development, many Lindapter products are independently fire tested in accordance with BS EN 1991-1-2.



Factory Mutual

This American insurance organisation offers an approval that is recognised by the fire protection industry worldwide.



VdS Schadenverhütung GmbH

VdS is a leading independent testing institution in Germany for products used in fire protection applications.



ICC-ES

North America's leading evaluation service has approved multiple Lindapter products to be compliant with the International Building Code.



Dynamic Load Approval

Lindapter has gained independent ETA / CE Mark approval for Types A, B, AF and AAF when used in dynamic load applications.



Lloyd's Register Type Approval

Products subjected to tensile, frictional, vibration and shock tests, witnessed and verified by Lloyd's Register.



TÜV Nord

TÜV is the certifying authority for safety, quality and environmental protection in Germany.

QUALITY, ENVIRONMENT & TRACEABILITY

Accredited to **ISO 9001** since 1986, Lindapter strictly enforces a quality management system that includes rigorous product testing to ensure consistently high manufacturing standards. As part of Lindapter's ISO 9001 quality management system and in compliance with the Construction Products Regulation, Lindapter operates a comprehensive Factory Production Control system that ensures traceability of all Lindapter products throughout the manufacturing process.



The company also operates an **ISO 14001** certified environmental management system, constantly monitoring and improving aspects of the business that may impact on the environment, such as the use of natural resources as well as handling and treatment of waste and energy consumption.



Disclaimer Lindapter International supplies components in good faith, on the assumption that customers fully understand the loadings, safety factors and physical parameters of the products involved. Customers or users who are unaware or unsure of any details should refer to Lindapter International before use. Responsibility for loss, damage, or other consequences of misuse cannot be accepted. Lindapter makes every effort to ensure that technical specifications and other product descriptions are correct. 'Specification' shall mean the specification (relating to the use of the materials) set out in the quotation given by the Seller to the Buyer. Responsibility for errors or omissions cannot be accepted. All dimensions stated are subject to production tolerances - if in doubt please check with Lindapter. In the interests of improving the quality and performance of Lindapter products, we reserve the right to make specification changes without prior notice.

© Lindapter International 2026 LINDAPTER is a registered trademark. Lindapter may also have trademark rights in other terms used herein.



Ask Lindapter to design a solution
to your connection requirements:

Tel: +44 (0) 1274 521444

General Enquiries: enquiries@Lindapter.com

Technical Support: support@Lindapter.com

