

4.7 Les écrous

Écrous hexagonaux

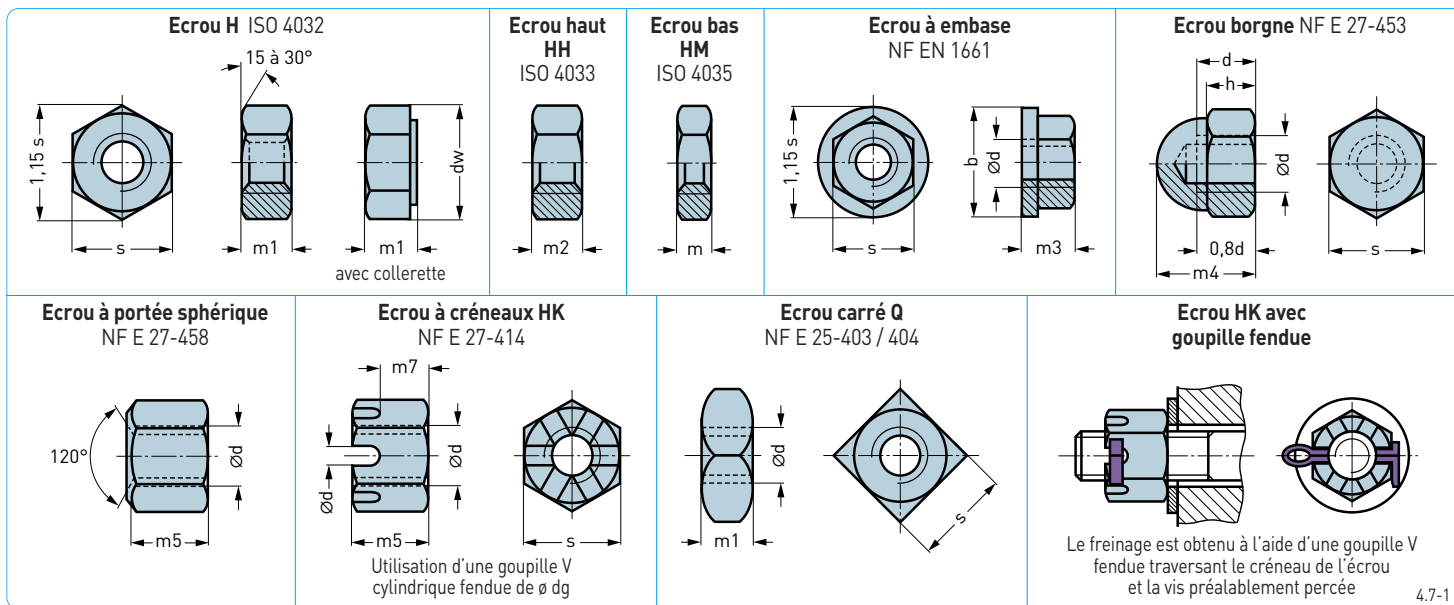

Écrous élastiques en tôle NFE 27-460

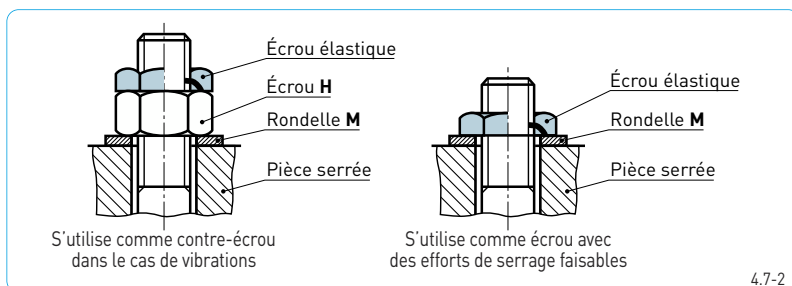

Utilisation de deux écrous

Évite le desserrage de l'ensemble

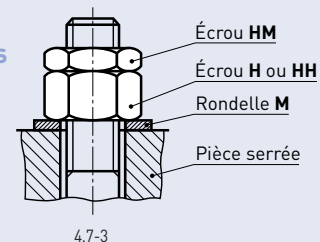

Ecrous autofreinés

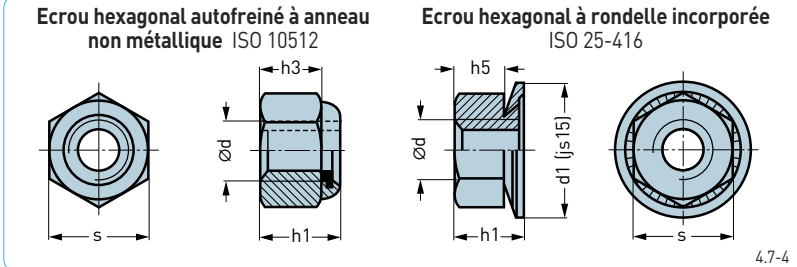

Ecrous à sertir pour tôle

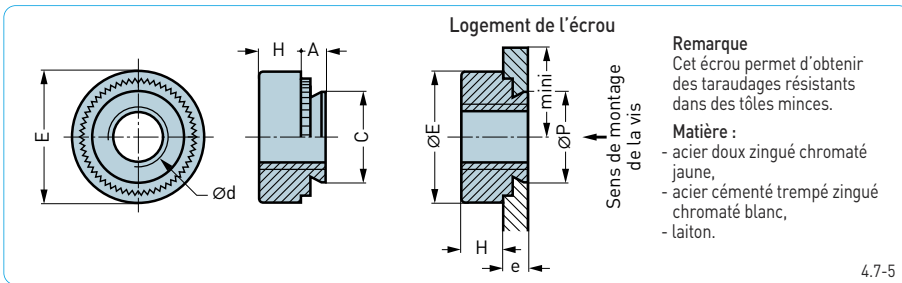

Désignation

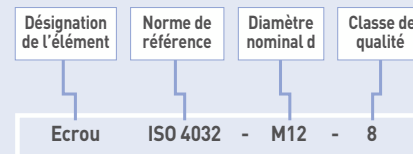

Ecrous et rondelles à encoches

